

# SK<sup>+</sup>/SPK<sup>+</sup> –

New right-angle precision as classic shaft version



The successor to our versatile hypoid gearhead with SP<sup>+</sup> compatible output shaft, also available with planetary stage (SPK<sup>+</sup>).

## Quick size selection

**SK<sup>+</sup>** (example for  $i = 5$ )  
For applications in cyclic operation ( $ED \leq 60\%$ )

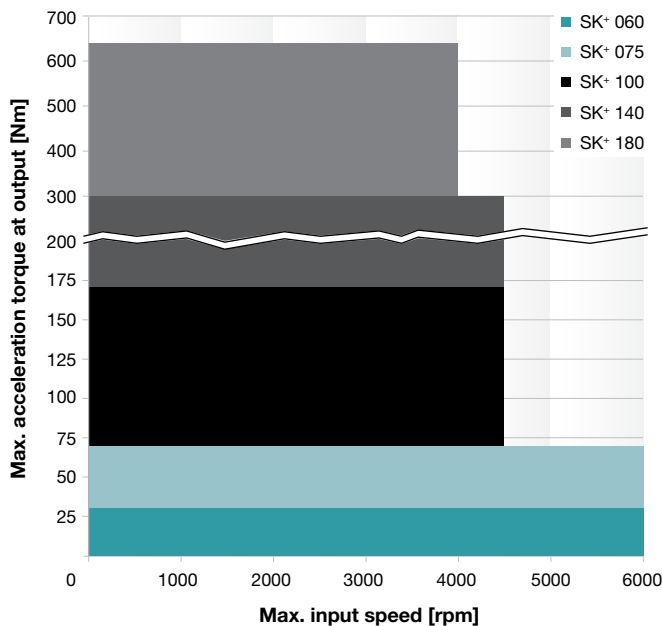

**SPK<sup>+</sup>** (example for  $i = 25$ )  
For applications in cyclic operation ( $ED \leq 60\%$ )

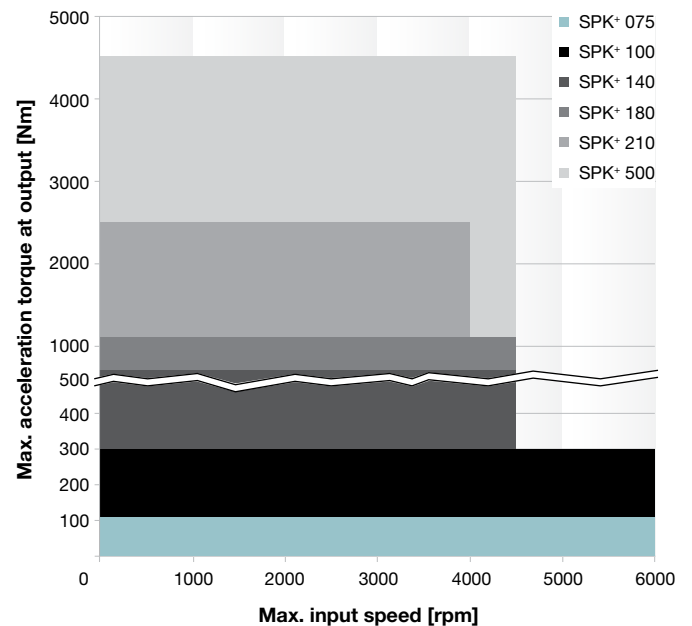

# Versions and Applications

## SK+

- Cyclic applications
- Reverse operation
- Highly dynamic applications
- High positioning accuracy

## SPK+

- Maximum power density
- Maximum positioning accuracy

## Comparison

Features		SK+ from page 200	SPK+ from page 210
Ratios <sup>c)</sup>		3 – 100	12 – 10000
Torsional backlash [arcmin] <sup>c)</sup>	Standard	≤ 4	≤ 4
	Reduced	–	–
<b>Output type</b>			
Smooth output shaft		•	•
Smooth output shaft, rear side		•	•
Keywayed output shaft		•	•
Keywayed output shaft, rear side		•	•
Output shaft with involute gearing		•	•
Hollow shaft interface, rear side Connected via shrink disc		•	•
Mounted shaft Connected via shrink disc		•	•
Closed cover, rear side		•	•
<b>Input type</b>			
Motor mounted version		•	•
<b>Type</b>			
ATEX <sup>a)</sup>		•	•
Food-grade lubrication <sup>a) b)</sup>		•	•
Corrosion resistant <sup>a) b)</sup>		•	•
<b>Accessories</b>			
Coupling		•	•
Rack		•	•
Pinion		•	•
Shrink disc		•	•
torqXis sensor flange		•	•
Intermediate plate for cooling connection		•	•

<sup>a)</sup> Power reduction: technical data available upon request    <sup>b)</sup> Please contact WITTENSTEIN alpha    <sup>c)</sup> In relation to reference sizes



# SK+ 060 MF 1/2-stage

		1-stage					2-stage											
Ratio <sup>a)</sup>	<i>i</i>	3	4	5	7	10	12	16	20	25	28	35	40	50	70	100		
Max. acceleration torque (max. 1000 cycles per hour)	$T_{2B}$	Nm	30	30	30	25	20	30	30	30	30	30	30	30	25	20		
		in.lb	266	266	266	221	177	266	266	266	266	266	266	266	266	221	177	
Nominal output torque (with $n_{1N}$ )	$T_{2N}$	Nm	22	22	22	20	15	22	22	22	22	22	22	22	20	15		
		in.lb	195	195	195	177	133	195	195	195	195	195	195	195	195	177	133	
Emergency stop torque (permitted 1000 times during the service life of the gearhead)	$T_{2Not}$	Nm	40	50	50	45	40	50	50	50	50	50	50	50	45	40		
		in.lb	354	443	443	398	354	443	443	443	443	443	443	443	443	398	354	
Nominal input speed (with $T_{2N}$ and 20°C ambient temperature) <sup>b), c)</sup>	$n_{1N}$	rpm	2500	2700	3000	3000	3000	4400	4400	4400	4400	4400	4400	4800	5500	5500		
Max. continuous speed (with 20% $T_{2N}$ and 20°C ambient temperature)	$n_{1Ncym}$	rpm	3000	3500	4000	3500	3500	5000	5000	5000	5000	5000	5000	5000	5500	5500		
Max. input speed	$n_{1Max}$	rpm	6000	6000	6000	6000	6000	6000	6000	6000	6000	6000	6000	6000	6000	6000		
Mean no load running torque (with $n_1=3000$ rpm and 20°C gearhead temperature) <sup>d)</sup>	$T_{01/2}$	Nm	1.2	1.1	1.0	1.2	1.1	0.2	0.2	0.2	0.2	0.2	0.2	0.1	0.1	0.1		
		in.lb	10.6	9.7	8.9	10.6	9.7	1.8	1.8	1.8	1.8	1.8	1.8	0.9	0.9	0.9		
Max. torsional backlash	$j_t$	arcmin	≤ 5															
Torsional rigidity	$C_{t21}$	Nm/arcmin	2.0	2.1	2.2	2.0	1.8	2.1	2.1	2.1	2.1	2.1	2.1	2.1	2.2	2.0		
		in.lb/arcmin	18	19	19	18	16	19	19	19	19	19	19	19	19	18		
Max. axial force <sup>e)</sup>	$F_{2AMax}$	N	2400															
		lb <sub>f</sub>	540															
Max. radial force <sup>e)</sup>	$F_{2RMax}$	N	2700															
		lb <sub>f</sub>	608															
Max. tilting moment	$M_{2KMax}$	Nm	251															
		in.lb	2220															
Efficiency at full load	$\eta$	%	96					94										
Service life (For calculation, see the Chapter "Information")	$L_h$	h	> 20000															
Weight incl. standard adapter plate	<i>m</i>	kg	2.9					3.2										
		lb <sub>m</sub>	6.4					7.1										
Operating noise (with $n_1=3000$ rpm no load)	$L_{PA}$	dB(A)	≤ 64															
Max. permitted housing temperature		°C	+90															
		F	194															
Ambient temperature		°C	0 to +40															
		F	32 to 104															
Lubrication			Lubricated for life															
Paint			Blue RAL 5002															
Direction of rotation			Motor and gearhead opposite directions															
Protection class			IP 65															
Moment of inertia (relates to the drive) Clamping hub diameter [mm]	B	11	$J_t$	kgcm <sup>2</sup>	-	-	-	-	-	0.09	0.09	0.07	0.07	0.06	0.06	0.06	0.06	
				10 <sup>-3</sup> in.lb.in <sup>2</sup>	-	-	-	-	-	0.08	0.08	0.07	0.06	0.06	0.06	0.05	0.05	0.05
	C	14	$J_t$	kgcm <sup>2</sup>	0.52	0.44	0.40	0.36	0.34	0.20	0.20	0.19	0.19	0.18	0.18	0.17	0.17	0.17
				10 <sup>-3</sup> in.lb.in <sup>2</sup>	0.46	0.39	0.35	0.32	0.30	0.18	0.18	0.17	0.16	0.16	0.16	0.15	0.15	0.15
E	19	$J_t$	kgcm <sup>2</sup>	0.87	0.79	0.75	0.71	0.70	-	-	-	-	-	-	-	-		
			10 <sup>-3</sup> in.lb.in <sup>2</sup>	0.77	0.70	0.66	0.63	0.62	-	-	-	-	-	-	-	-		

Please contact us for information on the best configuration for S1 conditions of use (continuous operation).

<sup>a)</sup> Other ratios available on request

<sup>b)</sup> Higher speeds are possible if the nominal torque is reduced

<sup>c)</sup> For higher ambient temperatures, please reduce input speed

<sup>d)</sup> Idling torques decrease during operation

<sup>e)</sup> Refers to center of the output shaft or flange

All technical data for front output side applies.

Technical data for rearward output versions, see page 386.

View A

1-stage:

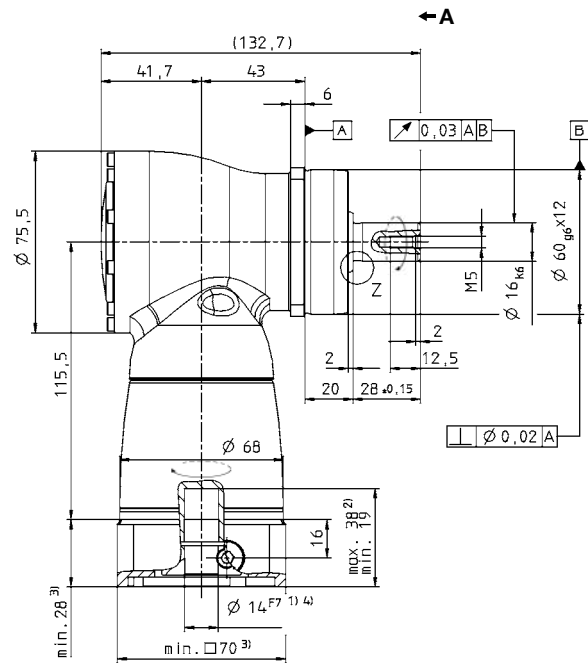
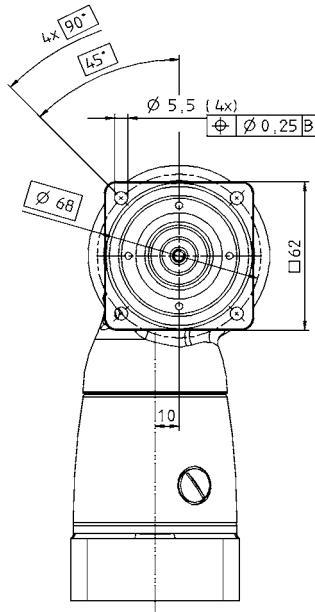

2-stage:

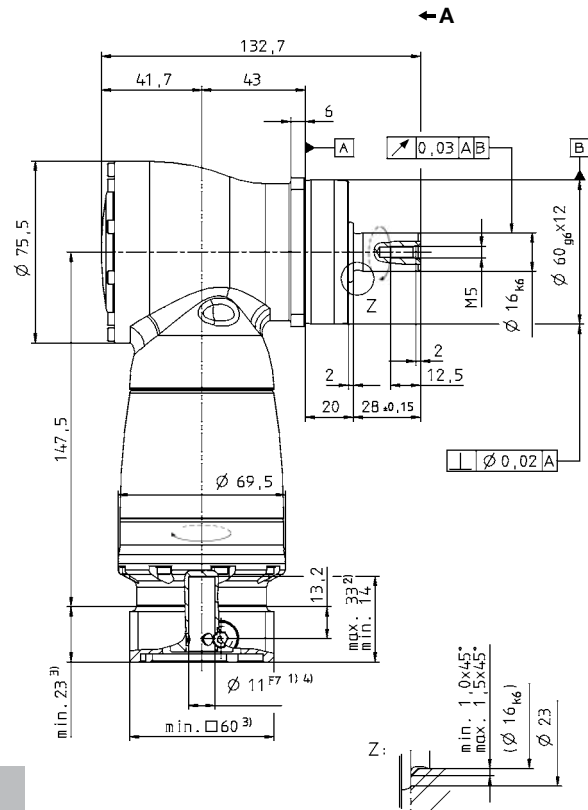
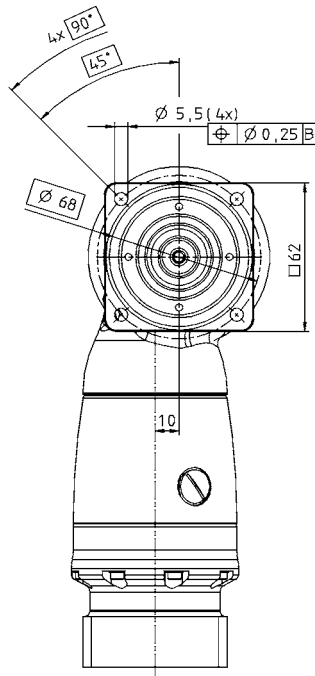

Alternatives: Output shaft variants

Keywayed output shaft in mm  
E = key as per DIN 6885, sheet 1, form A

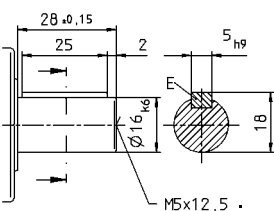

Involute gearing DIN 5480  
X = W 16 x 0.8 x 30 x 18 x 6m, DIN 5480

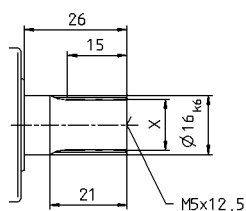

See technical data sheet for available clamping hub diameters (mass moment of inertia). Dimensions available on request.

Non-tolerated dimensions ±1 mm

- 1) Check motor shaft fit.
- 2) Min./Max. permissible motor shaft length. Longer motor shafts are adaptable, please contact us.
- 3) The dimensions depend on the motor.
- 4) Smaller motor shaft diameter is compensated by a bushing with a minimum thickness of 1 mm.

CAD data is available under [www.wittenstein-alpha.com](http://www.wittenstein-alpha.com)

Motor mounting according to operating manual

# SK+ 075 MF 1/2-stage

		1-stage					2-stage													
Ratio <sup>a)</sup>	<i>i</i>	3	4	5	7	10	12	16	20	25	28	35	40	50	70	100				
Max. acceleration torque (max. 1000 cycles per hour)	$T_{2B}$	Nm	70	70	70	60	50	70	70	70	70	70	70	70	60	50				
		in.lb	620	620	620	531	443	620	620	620	620	620	620	620	620	531	443			
Nominal output torque (with $n_{1N}$ )	$T_{2N}$	Nm	50	50	50	45	40	50	50	50	50	50	50	50	45	40				
		in.lb	443	443	443	398	354	443	443	443	443	443	443	443	443	398	354			
Emergency stop torque (permitted 1000 times during the service life of the gearhead)	$T_{2Not}$	Nm	95	115	115	110	100	115	115	115	115	115	115	115	110	100				
		in.lb	841	1018	1018	974	885	1018	1018	1018	1018	1018	1018	1018	1018	974	885			
Nominal input speed (with $T_{2N}$ and 20°C ambient temperature) <sup>b), c)</sup>	$n_{1N}$	rpm	2300	2500	2800	2800	2800	3500	3500	3500	3500	3500	3500	3500	3800	4500				
Max. continuous speed (with 20% $T_{2N}$ and 20°C ambient temperature)	$n_{1Ncym}$	rpm	3000	3500	4000	3500	3500	4500	4500	4500	4500	4500	4500	4500	4500	4500				
Max. input speed	$n_{1Max}$	rpm	6000	6000	6000	6000	6000	6000	6000	6000	6000	6000	6000	6000	6000	6000				
Mean no load running torque (with $n_1=3000$ rpm and 20°C gearhead temperature) <sup>d)</sup>	$T_{0/2}$	Nm	2.0	1.7	1.5	2.0	1.8	0.3	0.3	0.2	0.2	0.2	0.2	0.1	0.1	0.1				
		in.lb	18	15	13	18	16	2.7	2.7	1.8	1.8	1.8	1.8	0.9	0.9	0.9				
Max. torsional backlash	$j_t$	arcmin	≤ 4																	
Torsional rigidity	$C_{t21}$	Nm/arcmin	5.0	5.5	6.0	6.0	6.0	5.5	5.5	5.5	5.5	5.5	5.5	5.5	6.0	6.0	6.0			
		in.lb/arcmin	44	49	53	53	53	49	49	49	49	49	49	49	53	53	53			
Max. axial force <sup>e)</sup>	$F_{2AMax}$	N	3400																	
		lb <sub>f</sub>	765																	
Max. radial force <sup>e)</sup>	$F_{2RMMax}$	N	4000																	
		lb <sub>f</sub>	900																	
Max. tilting moment	$M_{2KMMax}$	Nm	437																	
		in.lb	3867																	
Efficiency at full load	$\eta$	%	96					94												
Service life (For calculation, see the Chapter "Information")	$L_h$	h	> 20000																	
Weight incl. standard adapter plate	<i>m</i>	kg	4.8					5.4												
		lb <sub>m</sub>	10.6					11.9												
Operating noise (with $n_1=3000$ rpm no load)	$L_{PA}$	dB(A)	≤ 66																	
Max. permitted housing temperature		°C	+90																	
		F	194																	
Ambient temperature		°C	0 to +40																	
		F	32 to 104																	
Lubrication			Lubricated for life																	
Paint			Blue RAL 5002																	
Direction of rotation			Motor and gearhead opposite directions																	
Protection class			IP 65																	
Moment of inertia (relates to the drive) Clamping hub diameter [mm]	C	14	$J_t$	kgcm <sup>2</sup>	-	-	-	-	-	0.28	0.27	0.23	0.23	0.20	0.20	0.18	0.18	0.18	0.18	
				10 <sup>-3</sup> in.lb.in <sup>2</sup>	-	-	-	-	-	0.25	0.24	0.21	0.20	0.18	0.18	0.16	0.16	0.16	0.16	
	E	19	$J_t$	kgcm <sup>2</sup>	1.46	1.19	1.06	0.95	0.90	0.73	0.71	0.68	0.67	0.63	0.62	0.63	0.63	0.63	0.63	0.63
				10 <sup>-3</sup> in.lb.in <sup>2</sup>	1.29	1.05	0.94	0.84	0.79	0.64	0.63	0.60	0.59	0.55	0.55	0.56	0.55	0.55	0.55	
H	28	$J_t$	kgcm <sup>2</sup>	2.88	2.61	2.47	2.37	2.31	-	-	-	-	-	-	-	-	-	-		
			10 <sup>-3</sup> in.lb.in <sup>2</sup>	2.55	2.31	2.19	2.10	2.04	-	-	-	-	-	-	-	-	-	-		

Please contact us for information on the best configuration for S1 conditions of use (continuous operation).

<sup>a)</sup> Other ratios available on request

<sup>b)</sup> Higher speeds are possible if the nominal torque is reduced

<sup>c)</sup> For higher ambient temperatures, please reduce input speed

<sup>d)</sup> Idling torques decrease during operation

<sup>e)</sup> Refers to center of the output shaft or flange

All technical data for front output side applies.

Technical data for rearward output versions, see page 386.

View A

1-stage:

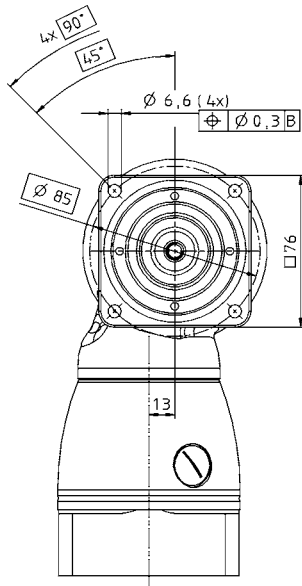

← A

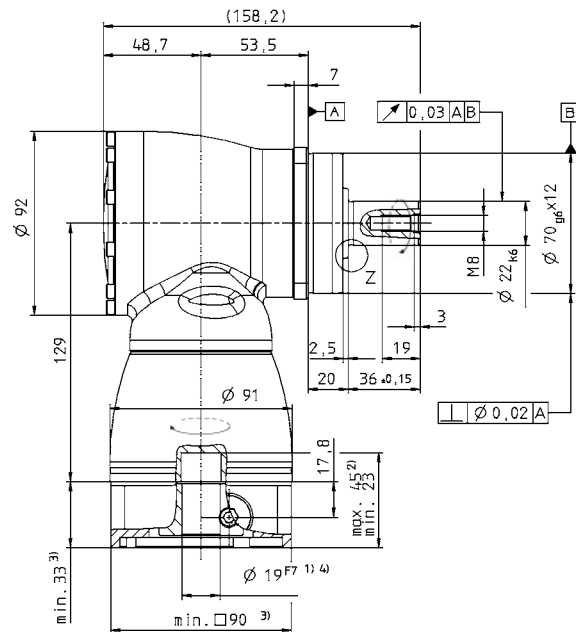

2-stage:

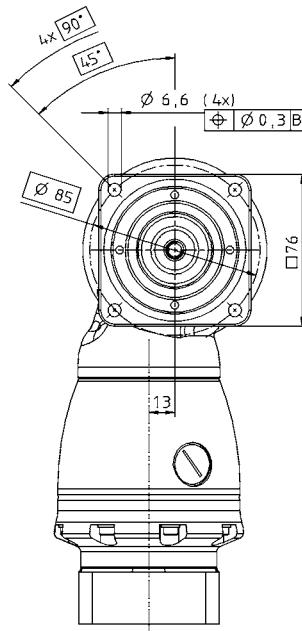

← A

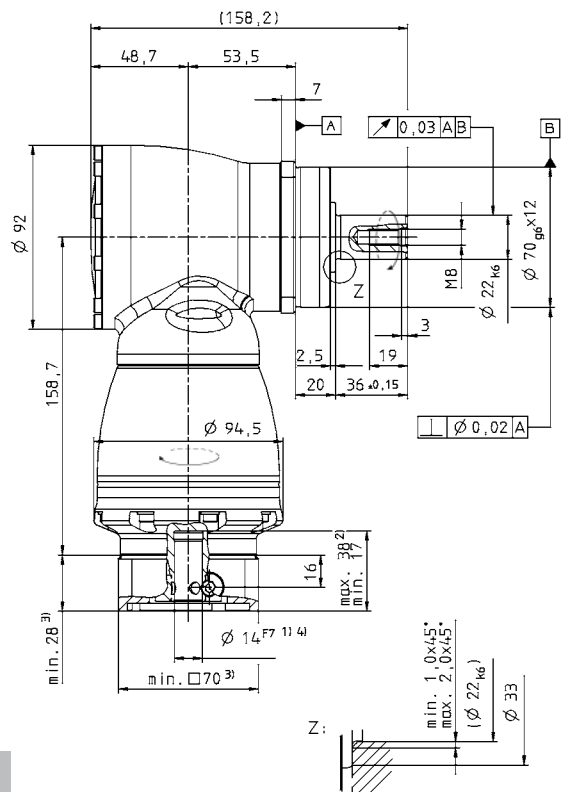

Alternatives: Output shaft variants

Keywayed output shaft in mm  
E = key as per DIN 6885, sheet 1, form A

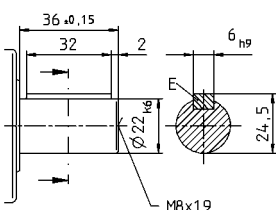

Involute gearing DIN 5480 in mm  
X = W 22 x 1.25 x 30 x 16 x 6m

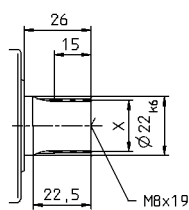

See technical data sheet for available clamping hub diameters (mass moment of inertia). Dimensions available on request.

Non-tolerated dimensions ±1 mm

- 1) Check motor shaft fit.
- 2) Min./Max. permissible motor shaft length. Longer motor shafts are adaptable, please contact us.
- 3) The dimensions depend on the motor.
- 4) Smaller motor shaft diameter is compensated by a bushing with a minimum thickness of 1 mm.

CAD data is available under [www.wittenstein-alpha.com](http://www.wittenstein-alpha.com)

Motor mounting according to operating manual

# SK+ 100 MF 1/2-stage

		1-stage					2-stage											
Ratio <sup>a)</sup>		<i>i</i>	3	4	5	7	10	12	16	20	25	28	35	40	50	70	100	
Max. acceleration torque (max. 1000 cycles per hour)	$T_{2B}$	Nm	170	170	170	145	125	170	170	170	170	170	170	170	170	145	125	
		in.lb	1505	1505	1505	1283	1106	1505	1505	1505	1505	1505	1505	1505	1505	1283	1106	
Nominal output torque (with $n_{1N}$ )	$T_{2N}$	Nm	100	100	100	90	80	100	100	100	100	100	100	100	100	90	80	
		in.lb	885	885	885	797	708	885	885	885	885	885	885	885	885	797	708	
Emergency stop torque (permitted 1000 times during the service life of the gearhead)	$T_{2Not}$	Nm	220	260	260	255	250	260	260	260	260	260	260	260	260	255	250	
		in.lb	1947	2301	2301	2257	2213	2301	2301	2301	2301	2301	2301	2301	2301	2257	2213	
Nominal input speed (with $T_{2N}$ and 20°C ambient temperature) <sup>b), c)</sup>	$n_{1N}$	rpm	2200	2400	2700	2500	2500	3100	3100	3100	3100	3100	3100	3100	3500	4200	4200	
Max. continuous speed (with 20% $T_{2N}$ and 20°C ambient temperature)	$n_{1Ncym}$	rpm	3000	3400	3800	3400	3400	4000	4000	4000	4000	4000	4000	4000	4000	4200	4200	
Max. input speed	$n_{1Max}$	rpm	4500	4500	4500	4500	4500	4500	4500	4500	4500	4500	4500	4500	4500	4500	4500	
Mean no load running torque (with $n_1=3000$ rpm and 20°C gearhead temperature) <sup>d)</sup>	$T_{0/2}$	Nm	3.8	3.0	2.3	3.5	2.8	0.6	0.6	0.5	0.4	0.4	0.3	0.2	0.2	0.2	0.2	
		in.lb	34	27	20	31	25	5.3	5.3	4.4	3.5	3.5	2.7	1.8	1.8	1.8	1.8	
Max. torsional backlash	$j_t$	arcmin	≤ 4															
Torsional rigidity	$C_{t21}$	Nm/arcmin	10	11	13	13	13	11	11	11	11	11	11	11	13	13	13	
		in.lb/arcmin	89	97	115	115	115	97	97	97	97	97	97	97	115	115	115	
Max. axial force <sup>e)</sup>	$F_{2AMax}$	N	5700															
		lb <sub>f</sub>	1283															
Max. radial force <sup>e)</sup>	$F_{2RMax}$	N	6300															
		lb <sub>f</sub>	1418															
Max. tilting moment	$M_{2KMax}$	Nm	833															
		in.lb	7370															
Efficiency at full load	$\eta$	%	96					94										
Service life (For calculation, see the Chapter "Information")	$L_h$	h	> 20000															
Weight incl. standard adapter plate	<i>m</i>	kg	9.3					10.0										
		lb <sub>m</sub>	21					22										
Operating noise (with $n_1=3000$ rpm no load)	$L_{PA}$	dB(A)	≤ 66															
Max. permitted housing temperature		°C	+90															
		F	194															
Ambient temperature		°C	0 to +40															
		F	32 to 104															
Lubrication			Lubricated for life															
Paint			Blue RAL 5002															
Direction of rotation			Motor and gearhead opposite directions															
Protection class			IP 65															
Moment of inertia (relates to the drive) Clamping hub diameter [mm]	E 19	$J_t$	kgcm <sup>2</sup>	-	-	-	-	-	1.02	0.97	0.86	0.84	0.75	0.74	0.69	0.69	0.68	0.68
			10 <sup>-3</sup> in.lb.in <sup>2</sup>	-	-	-	-	-	0.91	0.86	0.76	0.74	0.66	0.66	0.61	0.61	0.60	0.60
	G 24	$J_t$	kgcm <sup>2</sup>	-	-	-	-	-	2.59	2.54	2.42	2.40	2.31	2.30	2.26	2.25	2.25	2.25
			10 <sup>-3</sup> in.lb.in <sup>2</sup>	-	-	-	-	-	2.29	2.25	2.14	2.13	2.05	2.04	2.00	1.99	1.99	1.99
H 28	$J_t$	kgcm <sup>2</sup>	4.64	3.80	3.34	2.98	2.79	-	-	-	-	-	-	-	-	-	-	
		10 <sup>-3</sup> in.lb.in <sup>2</sup>	4.10	3.36	2.95	2.64	2.47	-	-	-	-	-	-	-	-	-	-	
K 38	$J_t$	kgcm <sup>2</sup>	11.9	11.0	10.6	10.2	10.0	-	-	-	-	-	-	-	-	-	-	
		10 <sup>-3</sup> in.lb.in <sup>2</sup>	10.5	9.77	9.37	9.05	8.89	-	-	-	-	-	-	-	-	-	-	

Please contact us for information on the best configuration for S1 conditions of use (continuous operation).

<sup>a)</sup> Other ratios available on request

<sup>b)</sup> Higher speeds are possible if the nominal torque is reduced

<sup>c)</sup> For higher ambient temperatures, please reduce input speed

<sup>d)</sup> Idling torques decrease during operation

<sup>e)</sup> Refers to center of the output shaft or flange

All technical data for front output side applies.

Technical data for rearward output versions, see page 386.

View A

1-stage:

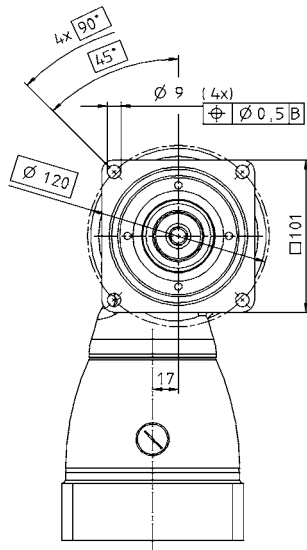

← A

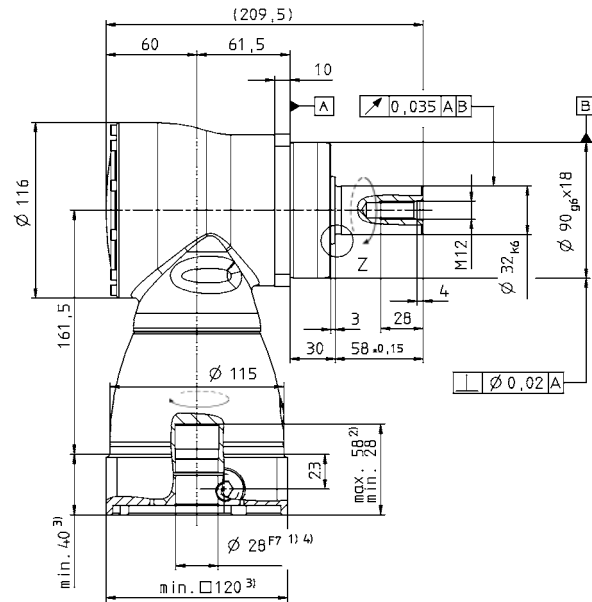

2-stage:

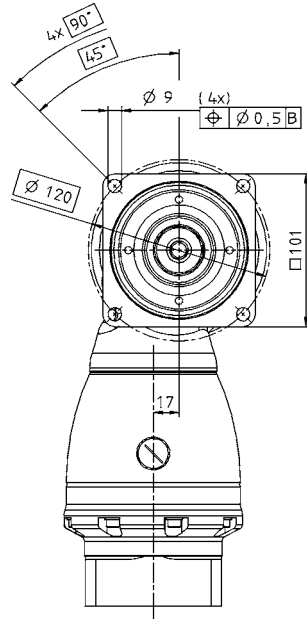

← A

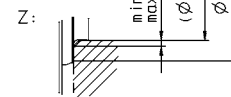
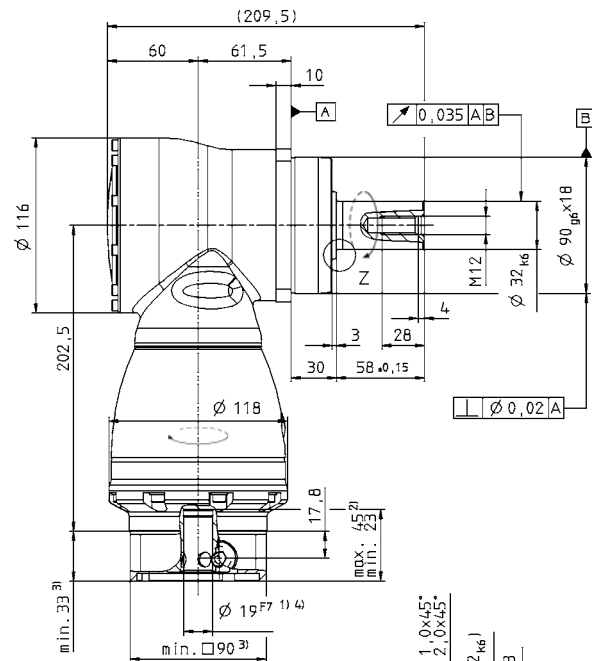

Alternatives: Output shaft variants

Keywayed output shaft in mm  
E = key as per DIN 6885, sheet 1, form A

Involute gearing DIN 5480  
X = W 32 x 1.25 x 30 x 24 x 6 mm

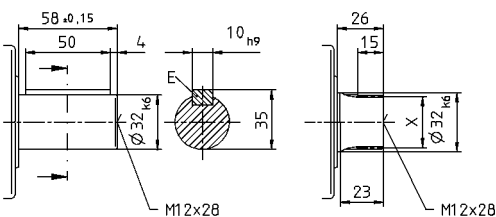

See technical data sheet for available clamping hub diameters (mass moment of inertia). Dimensions available on request.

Non-tolerated dimensions ±1 mm

- 1) Check motor shaft fit.
- 2) Min./Max. permissible motor shaft length. Longer motor shafts are adaptable, please contact us.
- 3) The dimensions depend on the motor.
- 4) Smaller motor shaft diameter is compensated by a bushing with a minimum thickness of 1 mm.

CAD data is available under [www.wittenstein-alpha.com](http://www.wittenstein-alpha.com)

Motor mounting according to operating manual

Right-angle gearheads  
High End

SK+



# SK+ 140 MF 1/2-stage

		1-stage					2-stage											
Ratio <sup>a)</sup>	<i>i</i>	3	4	5	7	10	12	16	20	25	28	35	40	50	70	100		
Max. acceleration torque (max. 1000 cycles per hour)	$T_{2B}$	Nm	300	300	300	250	210	300	300	300	300	300	300	300	300	250	210	
		in.lb	2655	2655	2655	2213	1859	2655	2655	2655	2655	2655	2655	2655	2655	2213	1859	
Nominal output torque (with $n_{1N}$ )	$T_{2N}$	Nm	190	190	190	175	160	190	190	190	190	190	190	190	190	175	160	
		in.lb	1682	1682	1682	1549	1416	1682	1682	1682	1682	1682	1682	1682	1682	1549	1416	
Emergency stop torque (permitted 1000 times during the service life of the gearhead)	$T_{2Not}$	Nm	400	500	500	450	400	500	500	500	500	500	500	500	500	450	400	
		in.lb	3540	4425	4425	3983	3540	4425	4425	4425	4425	4425	4425	4425	4425	3983	3540	
Nominal input speed (with $T_{2N}$ and 20°C ambient temperature) <sup>b), c)</sup>	$n_{1N}$	rpm	1900	2000	2200	2000	2000	2900	2900	2900	2900	2900	2900	2900	3200	3200	3900	
Max. continuous speed (with 20% $T_{2N}$ and 20°C ambient temperature)	$n_{1Ncym}$	rpm	2500	2800	3100	2800	2800	4000	4000	4000	4000	4000	4000	4000	4200	4200	4200	
Max. input speed	$n_{1Max}$	rpm	4500	4500	4500	4500	4500	4500	4500	4500	4500	4500	4500	4500	4500	4500	4500	
Mean no load running torque (with $n_1=3000$ rpm and 20°C gearhead temperature) <sup>d)</sup>	$T_{01/2}$	Nm	7.0	5.2	4.5	7.5	5.5	1.4	0.9	0.7	0.5	0.5	0.4	0.4	0.3	0.3	0.3	
		in.lb	62	46	40	66	49	12.4	8	6.2	4.4	4.4	3.5	3.5	2.7	2.7	2.7	
Max. torsional backlash	$j_t$	arcmin	≤ 4															
Torsional rigidity	$C_{t21}$	Nm/arcmin	27	30	32	32	32	29	29	29	29	29	29	29	31	31	31	
		in.lb/arcmin	239	266	283	283	283	257	257	257	257	257	257	257	274	274	274	
Max. axial force <sup>e)</sup>	$F_{2AMax}$	N	9900															
		lb <sub>f</sub>	2228															
Max. radial force <sup>e)</sup>	$F_{2RMMax}$	N	9500															
		lb <sub>f</sub>	2138															
Max. tilting moment	$M_{2KMMax}$	Nm	1692															
		in.lb	14974															
Efficiency at full load	$\eta$	%	96					94										
Service life (For calculation, see the Chapter "Information")	$L_h$	h	> 20000															
Weight incl. standard adapter plate	<i>m</i>	kg	22.6					25.0										
		lb <sub>m</sub>	50					55										
Operating noise (with $n_1=3000$ rpm without load)	$L_{PA}$	dB(A)	≤ 68															
Max. permitted housing temperature		°C	+90															
		F	194															
Ambient temperature		°C	0 to +40															
		F	32 to 104															
Lubrication			Lubricated for life															
Paint			Blue RAL 5002															
Direction of rotation			Motor and gearhead opposite directions															
Protection class			IP 65															
Moment of inertia (relates to the drive) Clamping hub diameter [mm]	G 24	$J_1$	kgcm <sup>2</sup>	-	-	-	-	-	4.21	3.85	3.28	3.17	2.78	2.73	2.48	2.46	2.43	2.42
			10 <sup>-3</sup> in.lb.s <sup>2</sup>	-	-	-	-	-	3.73	3.41	2.90	2.80	2.46	2.41	2.20	2.17	2.15	2.14
	K 38	$J_1$	kgcm <sup>2</sup>	25.0	19.1	16.3	14.1	12.8	11.1	10.7	10.2	10.1	9.69	9.64	9.39	9.37	9.34	9.33
			10 <sup>-3</sup> in.lb.s <sup>2</sup>	22.1	16.9	14.4	12.4	11.3	9.83	9.51	9.01	8.92	8.58	8.53	8.31	8.29	8.27	8.26

<sup>a)</sup> Other ratios available on request

<sup>b)</sup> Higher speeds are possible if the nominal torque is reduced

<sup>c)</sup> For higher ambient temperatures, please reduce input speed

<sup>d)</sup> Idling torques decrease during operation

<sup>e)</sup> Refers to center of the output shaft or flange

All technical data for front output side applies.

Technical data for rearward output versions, see page 386.

Please contact us for information on the best configuration for S1 conditions of use (continuous operation).

View A

1-stage:

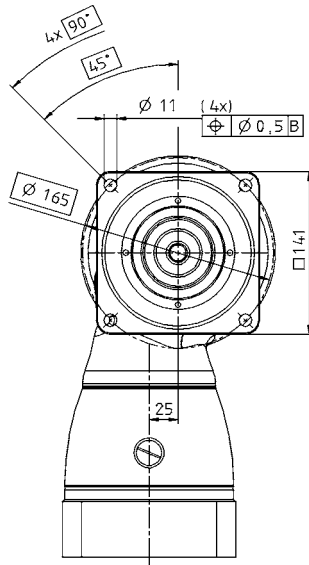

← A

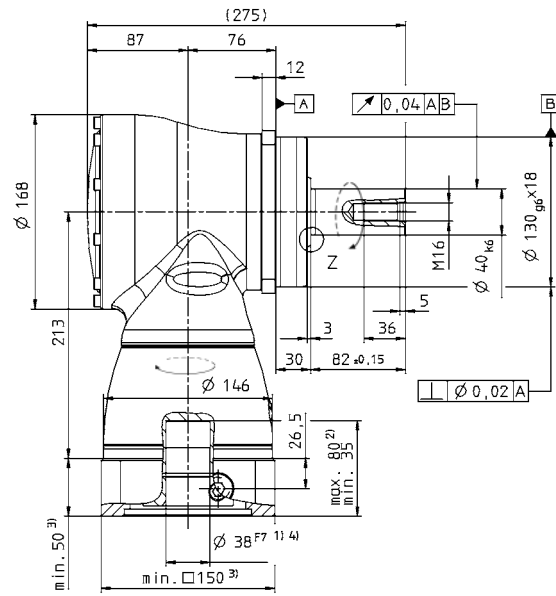

2-stage:

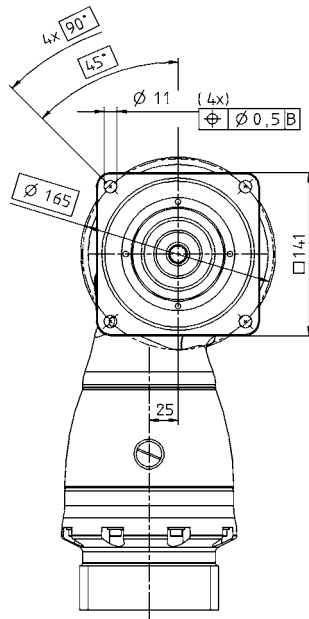

← A

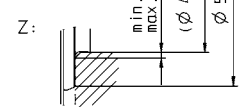
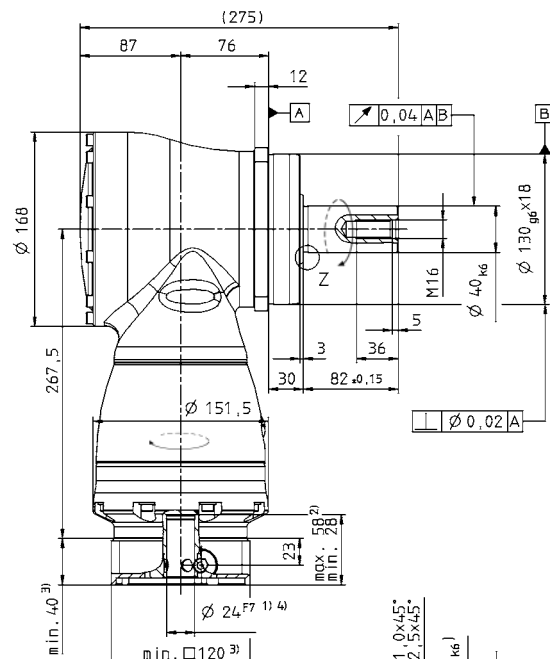

Right-angle gearheads  
High End

SK+

Alternatives: Output shaft variants

Keywayed output shaft in mm  
E = key as per DIN 6885, sheet 1, form A

Involute gearing DIN 5480  
X = W 40 x 2 x 30 x 18 x 6 mm

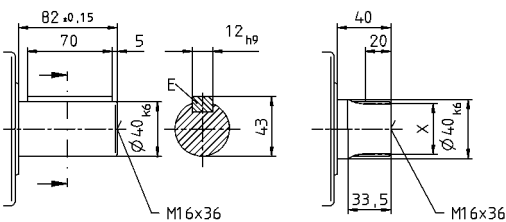

See technical data sheet for available clamping hub diameters (mass moment of inertia). Dimensions available on request.

Non-tolerated dimensions ±1 mm

- 1) Check motor shaft fit.
- 2) Min./Max. permissible motor shaft length. Longer motor shafts are adaptable, please contact us.
- 3) The dimensions depend on the motor.
- 4) Smaller motor shaft diameter is compensated by a bushing with a minimum thickness of 1 mm.

CAD data is available under [www.wittenstein-alpha.com](http://www.wittenstein-alpha.com)

Motor mounting according to operating manual

# SK+ 180 MF 1/2-stage

		1-stage					2-stage												
Ratio <sup>a)</sup>		<i>i</i>	3	4	5	7	10	12	16	20	25	28	35	40	50	70	100		
Max. acceleration torque (max. 1000 cycles per hour)	$T_{2B}$	Nm	640	640	640	550	470	640	640	640	640	640	640	640	640	550	470		
		in.lb	5664	5664	5664	4868	4160	5664	5664	5664	5664	5664	5664	5664	5664	5664	4868	4160	
Nominal output torque (with $n_{1N}$ )	$T_{2N}$	Nm	400	400	400	380	360	400	400	400	400	400	400	400	400	380	360		
		in.lb	3540	3540	3540	3363	3186	3540	3540	3540	3540	3540	3540	3540	3540	3540	3363	3186	
Emergency stop torque (permitted 1000 times during the service life of the gearhead)	$T_{2Not}$	Nm	900	1050	1050	970	900	1050	1050	1050	1050	1050	1050	1050	1050	970	900		
		in.lb	7965	9293	9293	8585	7965	9293	9293	9293	9293	9293	9293	9293	9293	8585	7965		
Nominal input speed (with $T_{2N}$ and 20°C ambient temperature) <sup>b), c)</sup>	$n_{1N}$	rpm	1600	1800	2000	1800	1800	2700	2700	2700	2700	2700	2700	2700	2900	3200	3400		
Max. continuous speed (with 20% $T_{2N}$ and 20°C ambient temperature)	$n_{1Ncym}$	rpm	2000	2400	2800	2500	2500	3500	3500	3500	3500	3500	3500	3500	3500	3800	3800		
Max. input speed	$n_{1Max}$	rpm	4000	4000	4000	4000	4000	4000	4000	4000	4000	4000	4000	4000	4000	4000	4000		
Mean no load running torque (with $n_1=3000$ rpm and 20°C gearhead temperature) <sup>d)</sup>	$T_{01/2}$	Nm	14.5	12.0	10.0	15.0	12.5	3.0	2.3	1.8	1.6	1.3	1.2	0.9	0.9	0.9	0.9		
		in.lb	128	106	89	133	111	26.6	20.4	15.9	14.2	11.5	10.6	8.0	8.0	8.0	8.0		
Max. torsional backlash	$j_t$	arcmin	≤ 4																
Torsional rigidity	$C_{t21}$	Nm/arcmin	64	71	79	78	77	71	71	71	71	71	71	71	71	78	78	78	
		in.lb/arcmin	566	628	699	690	681	628	628	628	628	628	628	628	628	690	690	690	
Max. axial force <sup>e)</sup>	$F_{2AMax}$	N	14200																
		lb <sub>f</sub>	3195																
Max. radial force <sup>e)</sup>	$F_{2RMMax}$	N	14700																
		lb <sub>f</sub>	3308																
Max. tilting moment	$M_{2KMMax}$	Nm	3213																
		in.lb	28435																
Efficiency at full load	$\eta$	%	96					94											
Service life (For calculation, see the Chapter "Information")	$L_h$	h	> 20000																
Weight incl. standard adapter plate	<i>m</i>	kg	45.4					48											
		lb <sub>m</sub>	100					106											
Operating noise (with $n_1=3000$ rpm no load)	$L_{PA}$	dB(A)	≤ 68																
Max. permitted housing temperature		°C	+90																
		F	194																
Ambient temperature		°C	0 to +40																
		F	32 to 104																
Lubrication			Lubricated for life																
Paint			Blue RAL 5002																
Direction of rotation			Motor and gearhead opposite directions																
Protection class			IP 65																
Moment of inertia (relates to the drive) Clamping hub diameter [mm]	K	38	$J_1$	kgcm <sup>2</sup>	-	-	-	-	-	15.3	14.0	12.3	12.0	10.9	10.7	10.1	10.0	9.95	9.91
				10 <sup>-3</sup> in.lb.s <sup>2</sup>	-	-	-	-	-	13.6	12.3	10.9	10.6	9.65	9.48	8.96	8.88	8.81	8.77
	M	48	$J_1$	kgcm <sup>2</sup>	73.3	51.6	42.1	34.0	29.7	30.0	28.7	27.1	26.7	25.6	25.4	24.8	24.7	24.7	24.6
				10 <sup>-3</sup> in.lb.s <sup>2</sup>	64.9	45.6	37.3	30.1	26.3	26.6	25.4	23.9	23.6	22.7	22.5	22.0	21.9	21.8	21.8

<sup>a)</sup> Other ratios available on request

<sup>b)</sup> Higher speeds are possible if the nominal torque is reduced

<sup>c)</sup> For higher ambient temperatures, please reduce input speed

<sup>d)</sup> Idling torques decrease during operation

<sup>e)</sup> Refers to center of the output shaft or flange

All technical data for front output side applies.

Technical data for rearward output versions, see page 386.

Please contact us for information on the best configuration for S1 conditions of use (continuous operation).

View A

1-stage:

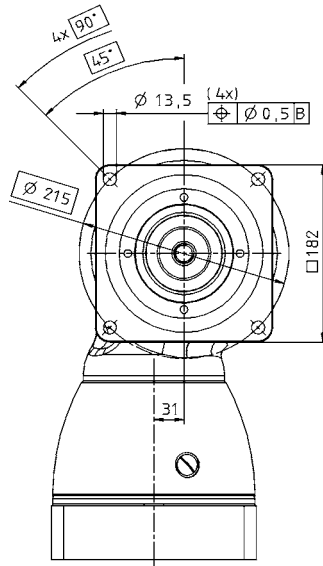

← A

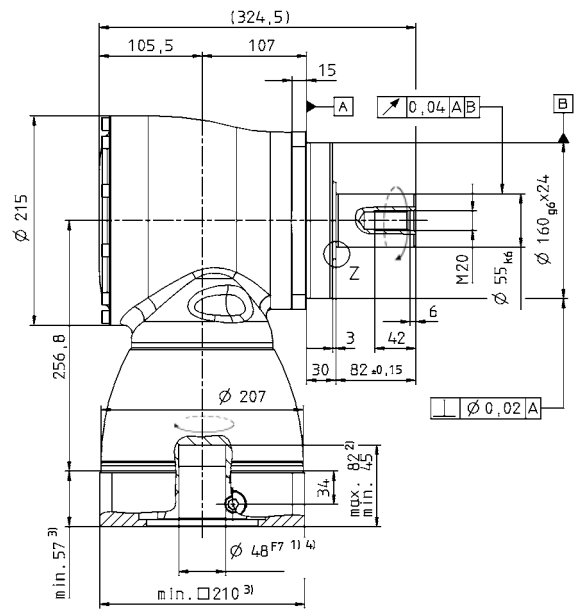

2-stage:

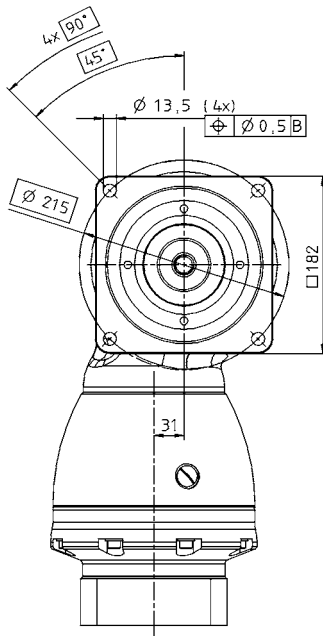

← A

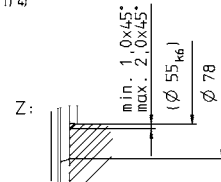
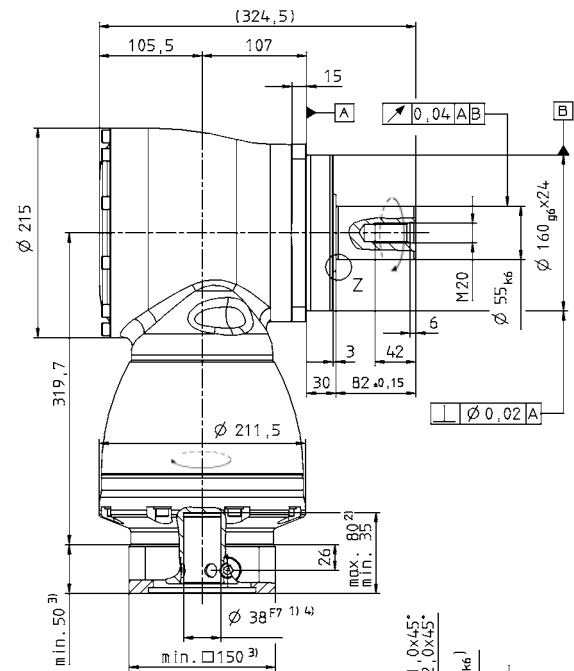

Right-angle gearheads  
High End

SK+

Alternatives: Output shaft variants

Keywayed output shaft in mm  
E = key as per DIN 6885, sheet 1, form A

Involute gearing DIN 5480  
X = W 55 x 2 x 30 x 26 x 6m

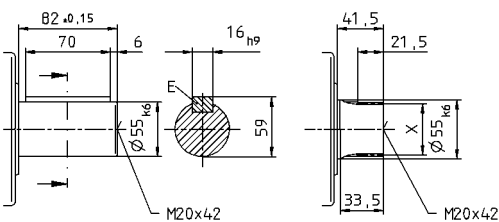

See technical data sheet for available clamping hub diameters (mass moment of inertia). Dimensions available on request.

Non-tolerated dimensions ±1 mm

- 1) Check motor shaft fit.
- 2) Min./Max. permissible motor shaft length. Longer motor shafts are adaptable, please contact us.
- 3) The dimensions depend on the motor.
- 4) Smaller motor shaft diameter is compensated by a bushing with a minimum thickness of 1 mm.

CAD data is available under [www.wittenstein-alpha.com](http://www.wittenstein-alpha.com)

Motor mounting according to operating manual

# SPK+ 075 MF 2-stage

		2-stage												
Ratio <sup>a)</sup>	<i>i</i>		12	16	20	25	28	35	40	50	70	100		
Max. acceleration torque (max. 1000 cycles per hour)	$T_{2B}$	Nm	110	110	110	110	110	110	80	100	110	90		
		in.lb	974	974	974	974	974	974	974	885	974	797		
Nominal output torque (with $n_{1N}$ )	$T_{2N}$	Nm	75	75	75	75	75	75	60	75	75	52		
		in.lb	664	664	664	664	664	664	531	664	664	460		
Emergency stop torque (permitted 1000 times during the service life of the gearhead)	$T_{2Not}$	Nm	160	160	200	200	250	175	120	150	210	200		
		in.lb	1416	1416	1770	1770	2213	1549	1062	1328	1859	1770		
Nominal input speed (with $T_{2N}$ and 20°C ambient temperature) <sup>b), c)</sup>	$n_{1N}$	rpm	2000	2400	2400	2700	2400	2500	2500	2500	2500	2500		
Max. continuous speed (with 20% $T_{2N}$ and 20°C ambient temperature)	$n_{1Ncym}$	rpm	3000	3400	3400	3800	3400	3200	3200	3200	3200	3200		
Max. input speed	$n_{1Max}$	rpm	6000	6000	6000	6000	6000	6000	6000	6000	6000	6000		
Mean no load running torque (with $n_1=3000$ rpm and 20°C gearhead temperature) <sup>d)</sup>	$T_{01/2}$	Nm	1.5	1.3	1.2	1.2	1.2	1.3	1.3	1.3	1.3	1.3		
		in.lb	13.3	11.5	10.6	10.6	10.6	11.5	11.5	11.5	11.5	11.5		
Max. torsional backlash	$j_t$	arcmin	Standard $\leq 5$ / Reduced $\leq 3$											
Torsional rigidity	$C_{t21}$	Nm/ arcmin	10											
		in.lb/ arcmin	89											
Max. axial force <sup>e)</sup>	$F_{2AMax}$	N	3350											
		lb <sub>f</sub>	753											
Max. radial force <sup>e)</sup>	$F_{2RMax}$	N	4000											
		lb <sub>f</sub>	900											
Max. tilting moment	$M_{2KMax}$	Nm	236											
		in.lb	2089											
Efficiency at full load	$\eta$	%	94											
Service life (For calculation, see the Chapter "Information")	$L_h$	h	> 20000											
Weight incl. standard adapter plate	<i>m</i>	kg	5.2											
		lb <sub>m</sub>	11.5											
Operating noise (with $n_1 = 3000$ rpm no load)	$L_{PA}$	dB(A)	$\leq 66$											
Max. permitted housing temperature		°C	+90											
		F	194											
Ambient temperature		°C	0 to +40											
		F	32 to 104											
Lubrication			Lubricated for life											
Paint			Blue RAL 5002											
Direction of rotation			Motor and gearhead opposite directions											
Protection class			IP 65											
Moment of inertia (relates to the drive) Clamping hub diameter [mm]	C	14	$J_t$	kgcm <sup>2</sup>	0.54	0.45	0.44	0.40	0.44	0.36	0.35	0.34	0.34	0.34
				10 <sup>-3</sup> in.lb.s <sup>2</sup>	0.48	0.40	0.39	0.35	0.39	0.32	0.31	0.30	0.30	0.30
	E	19	$J_t$	kgcm <sup>2</sup>	0.89	0.80	0.79	0.75	0.79	0.71	0.70	0.70	0.70	0.69
				10 <sup>-3</sup> in.lb.s <sup>2</sup>	0.79	0.71	0.70	0.66	0.70	0.63	0.62	0.62	0.62	0.61

<sup>a)</sup> Other ratios up to  $i=1000$  available on request

<sup>b)</sup> Higher speeds are possible if the nominal torque is reduced

<sup>c)</sup> For higher ambient temperatures, please reduce input speed

<sup>d)</sup> Idling torques decrease during operation

<sup>e)</sup> Refers to center of the output shaft or flange

All technical data for front output side applies.

Technical data for rearward output versions, see page 386.

Please contact us for information on the best configuration for S1 conditions of use (continuous operation).

View A

2-stage:

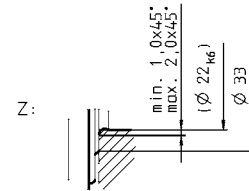
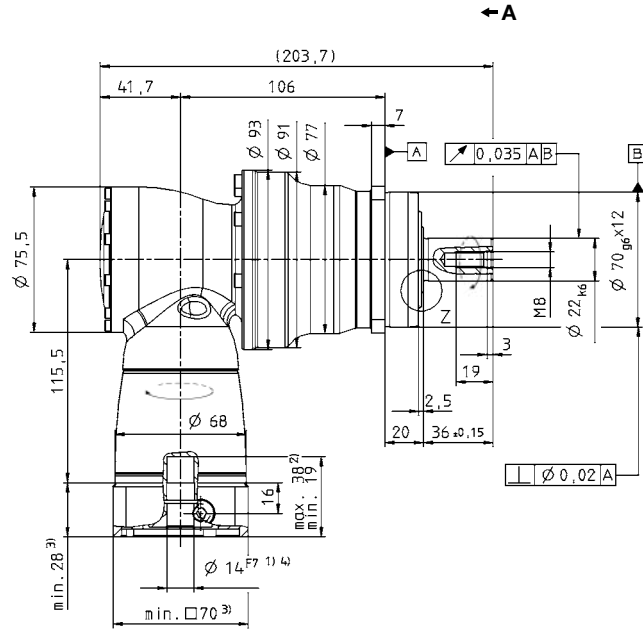
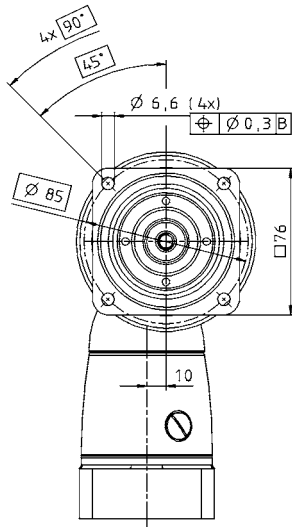

Right-angle gearheads  
High End

Alternatives: Output shaft variants

Keywayed output shaft in mm  
E = key as per DIN 6885, sheet 1, form A

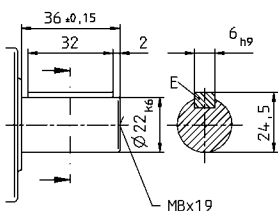

Involute gearing DIN 5480 in mm  
X = W 22 x 1.25 x 30 x 16 x 6m, DIN 5480

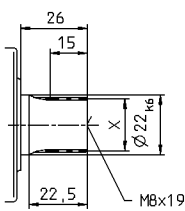

Shaft mounted  
Mounted via shrink disc

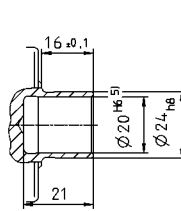

See technical data sheet for available clamping hub diameters (mass moment of inertia). Dimensions available on request.

Non-tolerated dimensions ±1 mm

- 1) Check motor shaft fit.
- 2) Min./Max. permissible motor shaft length. Longer motor shafts are adaptable, please contact us.
- 3) The dimensions depend on the motor.
- 4) Smaller motor shaft diameter is compensated by a bushing with a minimum thickness of 1 mm.

CAD data is available under [www.wittenstein-alpha.com](http://www.wittenstein-alpha.com)

Motor mounting according to operating manual

SPK+

# SPK+ 075 MF 3-stage

		3-stage															
Ratio <sup>a)</sup>		<i>i</i>	64	84	100	125	140	175	200	250	280	350	400	500	700	1000	
Max. acceleration torque (max. 1000 cycles per hour)	$T_{2B}$	Nm	110	110	110	110	110	110	110	110	110	110	80	100	110	90	
		in.lb	974	974	974	974	974	974	974	974	974	974	974	708	885	974	797
Nominal output torque (with $n_{1N}$ )	$T_{2N}$	Nm	75	75	75	75	75	75	75	75	75	75	60	75	75	52	
		in.lb	664	664	664	664	664	664	664	664	664	664	664	531	664	664	460
Emergency stop torque (permitted 1000 times during the service life of the gearhead)	$T_{2Not}$	Nm	160	160	200	200	200	200	200	200	200	250	175	120	150	210	200
		in.lb	1416	1416	1770	1770	1770	1770	1770	1770	1770	2213	1549	1062	1328	1859	1770
Nominal input speed (with $T_{2N}$ and 20°C ambient temperature) <sup>b), c)</sup>	$n_{1N}$	rpm	4400	4400	4400	4400	4400	4400	4400	4800	4400	4800	5500	5500	5500	5500	
Max. continuous speed (with 20% $T_{2N}$ and 20°C ambient temperature)	$n_{1Ncym}$	rpm	5000	5000	5000	5000	5000	5000	5000	5000	5000	5000	5500	5500	5500	5500	
Max. input speed	$n_{1Max}$	rpm	6000	6000	6000	6000	6000	6000	6000	6000	6000	6000	6000	6000	6000	6000	
Mean no load running torque (with $n_1=3000$ rpm and 20°C gearhead temperature) <sup>d)</sup>	$T_{012}$	Nm	0.3	0.3	0.3	0.3	0.3	0.3	0.2	0.2	0.2	0.2	0.2	0.2	0.2	0.2	
		in.lb	2.7	2.7	2.7	2.7	2.7	2.7	1.8	1.8	1.8	1.8	1.8	1.8	1.8	1.8	1.8
Max. torsional backlash	$j_t$	arcmin	Standard $\leq 5$ / Reduced $\leq 3$														
Torsional rigidity	$C_{t21}$	Nm/ arcmin	10														
		in.lb/ arcmin	89														
Max. axial force <sup>e)</sup>	$F_{2AMax}$	N	3350														
		lb <sub>f</sub>	754														
Max. radial force <sup>e)</sup>	$F_{2RMax}$	N	4000														
		lb <sub>f</sub>	900														
Max. tilting moment	$M_{2KMax}$	Nm	236														
		in.lb	2089														
Efficiency at full load	$\eta$	%	92														
Service life (For calculation, see the Chapter "Information")	$L_h$	h	> 20000														
Weight incl. standard adapter plate	<i>m</i>	kg	5.5														
		lb <sub>m</sub>	12.2														
Operating noise (with $n_1 = 3000$ rpm no load)	$L_{PA}$	dB(A)	$\leq 66$														
Max. permitted housing temperature		°C	+90														
		F	194														
Ambient temperature		°C	0 to +40														
		F	32 to 104														
Lubrication			Lubricated for life														
Paint			Blue RAL 5002														
Direction of rotation			Motor and gearhead opposite directions														
Protection class			IP 65														
Moment of inertia (relates to the drive) Clamping hub diameter [mm]	B	11	$J_t$	kgcm <sup>2</sup>	0.09	0.07	0.08	0.07	0.06	0.06	0.06	0.06	0.06	0.06	0.06	0.06	0.06
				10 <sup>3</sup> in.lb.in <sup>2</sup>	0.08	0.06	0.07	0.06	0.05	0.05	0.05	0.05	0.05	0.05	0.05	0.05	0.05
	C	14	$J_t$	kgcm <sup>2</sup>	0.20	0.18	0.19	0.19	0.18	0.18	0.17	0.17	0.17	0.17	0.17	0.17	0.17
				10 <sup>3</sup> in.lb.in <sup>2</sup>	0.18	0.16	0.17	0.17	0.16	0.16	0.15	0.15	0.15	0.15	0.15	0.15	0.15

<sup>a)</sup> Other ratios up to  $i=1000$  available on request

<sup>b)</sup> Higher speeds are possible if the nominal torque is reduced

<sup>c)</sup> For higher ambient temperatures, please reduce input speed

<sup>d)</sup> Idling torques decrease during operation

<sup>e)</sup> Refers to center of the output shaft or flange

All technical data for front output side applies.

Technical data for rearward output versions, see page 386.

Please contact us for information on the best configuration for S1 conditions of use (continuous operation).

View A

3-stage:

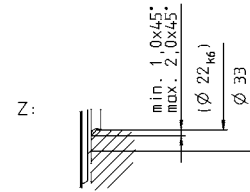
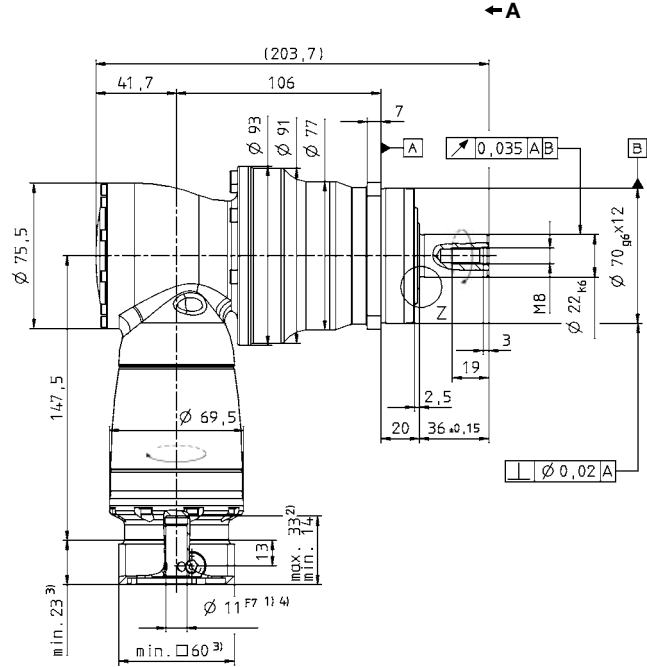
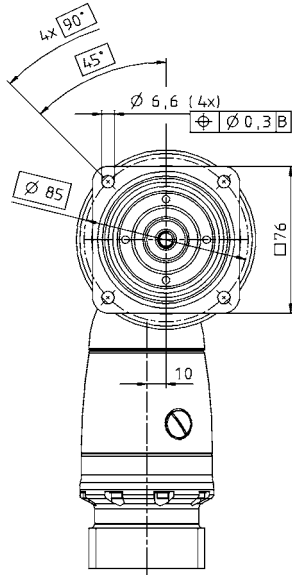

Right-angle gearheads  
High End

Alternatives: Output shaft variants

Keywayed output shaft in mm  
E = key as per DIN 6885, sheet 1, form A

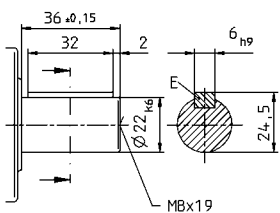

Involute gearing DIN 5480 in mm  
X = W 22 x 1.25 x 30 x 16 x 6m, DIN 5480

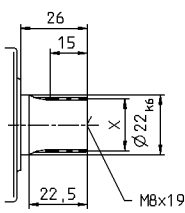

Shaft mounted  
Mounted via shrink disc

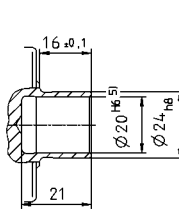

See technical data sheet for available clamping hub diameters (mass moment of inertia). Dimensions available on request.

Non-tolerated dimensions ±1 mm

- 1) Check motor shaft fit.
- 2) Min./Max. permissible motor shaft length. Longer motor shafts are adaptable, please contact us.
- 3) The dimensions depend on the motor.
- 4) Smaller motor shaft diameter is compensated by a bushing with a minimum thickness of 1 mm.

CAD data is available under [www.wittenstein-alpha.com](http://www.wittenstein-alpha.com)

Motor mounting according to operating manual

SPK+



# SPK+ 100 MF 2-stage

		2-stage												
Ratio <sup>a)</sup>	<i>i</i>		12	16	20	25	28	35	40	50	70	100		
Max. acceleration torque (max. 1000 cycles per hour)	$T_{2B}$	Nm	280	280	300	300	300	300	200	250	300	225		
		in.lb	2478	2478	2655	2655	2655	2655	1770	2213	2655	1991		
Nominal output torque (with $n_{1N}$ )	$T_{2N}$	Nm	180	180	175	175	170	175	160	175	170	120		
		in.lb	1593	1593	1549	1549	1505	1549	1416	1549	1505	1062		
Emergency stop torque (permitted 1000 times during the service life of the gearhead)	$T_{2Not}$	Nm	400	400	500	500	625	500	400	500	625	500		
		in.lb	3540	3540	4425	4425	5531	4425	3540	4425	5531	4425		
Nominal input speed (with $T_{2N}$ and 20°C ambient temperature) <sup>b), c)</sup>	$n_{1N}$	rpm	2000	2400	2400	2700	2400	2500	2500	2500	2500	2500		
Max. continuous speed (with 20% $T_{2N}$ and 20°C ambient temperature)	$n_{1Ncym}$	rpm	3000	3400	3400	3800	3400	3200	3200	3200	3200	3200		
Max. input speed	$n_{1Max}$	rpm	6000	6000	6000	6000	6000	6000	6000	6000	6000	6000		
Mean no load running torque (with $n_1=3000$ rpm and 20°C gearhead temperature) <sup>d)</sup>	$T_{012}$	Nm	2.5	2.1	2.0	1.8	2.0	2.2	2.0	2.0	2.0	2.0		
		in.lb	22.1	18.6	17.7	15.9	17.7	19.5	17.7	17.7	17.7	17.7		
Max. torsional backlash	$j_t$	arcmin	Standard $\leq 4$ / Reduced $\leq 2$											
Torsional rigidity	$C_{t21}$	Nm/ arcmin	31											
		in.lb/ arcmin	274											
Max. axial force <sup>e)</sup>	$F_{2AMax}$	N	5650											
		lb <sub>f</sub>	1271											
Max. radial force <sup>e)</sup>	$F_{2RMax}$	N	6300											
		lb <sub>f</sub>	1418											
Max. tilting moment	$M_{2KMax}$	Nm	487											
		in.lb	4310											
Efficiency at full load	$\eta$	%	94											
Service life (For calculation, see the Chapter "Information")	$L_h$	h	> 20000											
Weight incl. standard adapter plate	<i>m</i>	kg	9.7											
		lb <sub>m</sub>	21.4											
Operating noise (with $n_1 = 3000$ rpm no load)	$L_{PA}$	dB(A)	$\leq 68$											
Max. permitted housing temperature	°C		+90											
	F		194											
Ambient temperature	°C		0 to +40											
	F		32 to 104											
Lubrication	Lubricated for life													
Paint	Blue RAL 5002													
Direction of rotation	Motor and gearhead opposite directions													
Protection class	IP 65													
Moment of inertia (relates to the drive) Clamping hub diameter [mm]	E	19	$J_t$	kgcm <sup>2</sup>	1.48	1.20	1.17	1.05	1.15	0.95	0.90	0.89	0.89	0.89
				10 <sup>3</sup> in.lb.s <sup>2</sup>	1.31	1.06	1.04	0.93	1.02	0.84	0.79	0.79	0.79	0.78
	H	28	$J_t$	kgcm <sup>2</sup>	2.89	2.62	2.59	2.46	2.56	2.36	2.31	2.31	2.30	2.30
				10 <sup>3</sup> in.lb.s <sup>2</sup>	2.56	2.31	2.29	2.18	2.27	2.09	2.05	2.04	2.04	2.04

<sup>a)</sup> Other ratios up to  $i=1000$  available on request

<sup>b)</sup> Higher speeds are possible if the nominal torque is reduced

<sup>c)</sup> For higher ambient temperatures, please reduce input speed

<sup>d)</sup> Idling torques decrease during operation

<sup>e)</sup> Refers to center of the output shaft or flange

All technical data for front output side applies.

Technical data for rearward output versions, see page 386.

Please contact us for information on the best configuration for S1 conditions of use (continuous operation).

View A

2-stage:

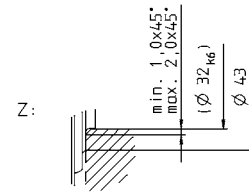
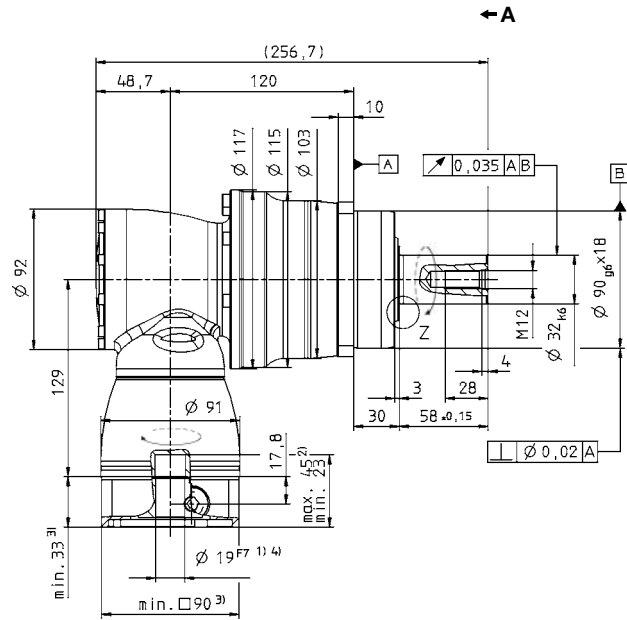
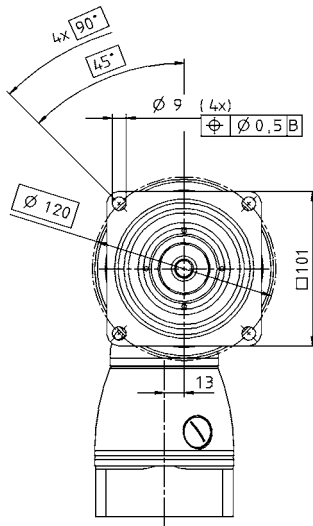

Right-angle gearheads  
High End

Alternatives: Output shaft variants

Keywayed output shaft in mm  
E = key as per DIN 6885, sheet 1, form A

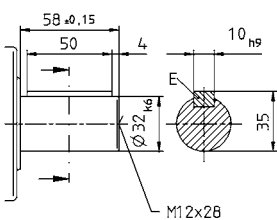

Involute gearing DIN 5480 in mm  
X = W 32 x 1.25 x 30 x 24 x 6m, DIN 5480

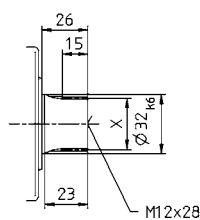

Shaft mounted  
Mounted via shrink disc

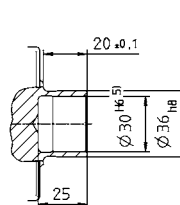

See technical data sheet for available clamping hub diameters (mass moment of inertia). Dimensions available on request.

Non-tolerated dimensions ±1 mm

- 1) Check motor shaft fit.
- 2) Min./Max. permissible motor shaft length. Longer motor shafts are adaptable, please contact us.
- 3) The dimensions depend on the motor.
- 4) Smaller motor shaft diameter is compensated by a bushing with a minimum thickness of 1 mm.

CAD data is available under [www.wittenstein-alpha.com](http://www.wittenstein-alpha.com)

Motor mounting according to operating manual

SPK+

# SPK+ 100 MF 3-stage

		3-stage															
Ratio <sup>a)</sup>		<i>i</i>	64	84	100	125	140	175	200	250	280	350	400	500	700	1000	
Max. acceleration torque (max. 1000 cycles per hour)	$T_{2B}$	Nm	280	280	300	300	300	300	300	300	300	300	200	250	300	225	
		in.lb	2478	2478	2655	2655	2655	2655	2655	2655	2655	2655	1770	2213	2655	1991	
Nominal output torque (with $n_m$ )	$T_{2N}$	Nm	180	180	175	175	175	175	175	175	170	175	160	175	170	120	
		in.lb	1593	1593	1549	1549	1549	1549	1549	1549	1505	1549	1416	1549	1505	1062	
Emergency stop torque (permitted 1000 times during the service life of the gearhead)	$T_{2Not}$	Nm	400	400	500	500	500	500	500	500	625	500	400	500	625	500	
		in.lb	3540	3540	4425	4425	4425	4425	4425	4425	5531	4425	3540	4425	5531	4425	
Nominal input speed (with $T_{2N}$ and 20°C ambient temperature) <sup>b), c)</sup>	$n_{1N}$	rpm	3500	3500	3500	3500	3500	3500	3500	3800	3500	3800	4500	4500	4500	4500	
Max. continuous speed (with 20% $T_{2N}$ and 20°C ambient temperature)	$n_{1Ncym}$	rpm	4500	4500	4500	4500	4500	4500	4500	4500	4500	4500	4500	4500	4500	4500	
Max. input speed	$n_{1Max}$	rpm	6000	6000	6000	6000	6000	6000	6000	6000	6000	6000	6000	6000	6000	6000	
Mean no load running torque (with $n_1=3000$ rpm and 20°C gearhead temperature) <sup>d)</sup>	$T_{01/2}$	Nm	0.4	0.3	0.3	0.3	0.3	0.3	0.2	0.2	0.2	0.2	0.2	0.2	0.2	0.2	
		in.lb	3.5	2.7	2.7	2.7	2.7	2.7	1.8	1.8	1.8	1.8	1.8	1.8	1.8	1.8	
Max. torsional backlash	$j_t$	arcmin	Standard $\leq 4$ / Reduced $\leq 2$														
Torsional rigidity	$C_{t21}$	Nm/ arcmin	31														
		in.lb/ arcmin	274														
Max. axial force <sup>e)</sup>	$F_{2AMax}$	N	5650														
		lb <sub>f</sub>	1271														
Max. radial force <sup>e)</sup>	$F_{2RMMax}$	N	6300														
		lb <sub>f</sub>	1418														
Max. tilting moment	$M_{2KMMax}$	Nm	487														
		in.lb	4310														
Efficiency at full load	$\eta$	%	92														
Service life (For calculation, see the Chapter "Information")	$L_h$	h	> 20000														
Weight incl. standard adapter plate	<i>m</i>	kg	10.3														
		lb <sub>m</sub>	22.8														
Operating noise (with $n_1 = 3000$ rpm no load)	$L_{PA}$	dB(A)	$\leq 68$														
Max. permitted housing temperature		°C	+90														
		F	194														
Ambient temperature		°C	0 to +40														
		F	32 to 104														
Lubrication			Lubricated for life														
Paint			Blue RAL 5002														
Direction of rotation			Motor and gearhead opposite directions														
Protection class			IP 65														
Moment of inertia (relates to the drive) Clamping hub diameter [mm]	C	14	$J_t$	kgcm <sup>2</sup>	0.28	0.23	0.24	0.23	0.21	0.20	0.19	0.18	0.19	0.18	0.18	0.18	0.18
				10 <sup>3</sup> in.lb.in <sup>2</sup>	0.25	0.20	0.21	0.20	0.19	0.18	0.17	0.16	0.17	0.16	0.16	0.16	0.16
	E	19	$J_t$	kgcm <sup>2</sup>	0.72	0.63	0.68	0.68	0.63	0.63	0.63	0.63	0.63	0.63	0.63	0.63	0.63
				10 <sup>3</sup> in.lb.in <sup>2</sup>	0.64	0.56	0.60	0.60	0.56	0.56	0.56	0.56	0.56	0.56	0.56	0.56	0.56

<sup>a)</sup> Other ratios up to  $i=1000$  available on request

<sup>b)</sup> Higher speeds are possible if the nominal torque is reduced

<sup>c)</sup> For higher ambient temperatures, please reduce input speed

<sup>d)</sup> Idling torques decrease during operation

<sup>e)</sup> Refers to center of the output shaft or flange

All technical data for front output side applies.

Technical data for rearward output versions, see page 386.

Please contact us for information on the best configuration for S1 conditions of use (continuous operation).

View A

3-stage:

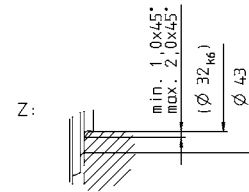
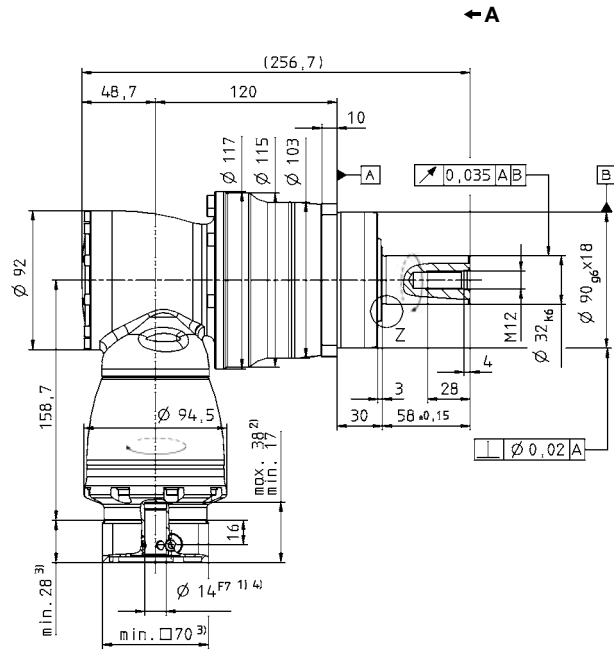
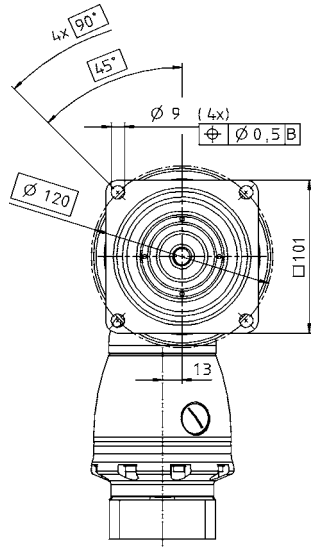

Right-angle gearheads  
High End

Alternatives: Output shaft variants

Keywayed output shaft in mm  
E = key as per DIN 6885, sheet 1, form A

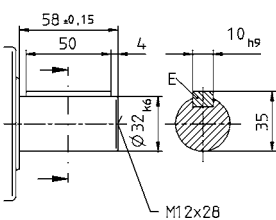

Involute gearing DIN 5480 in mm  
X = W 32 x 1.25 x 30 x 24 x 6m, DIN 5480

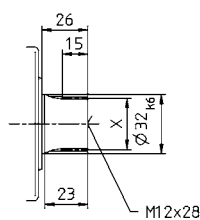

Shaft mounted  
Mounted via shrink disc

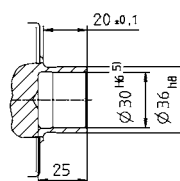

See technical data sheet for available clamping hub diameters (mass moment of inertia). Dimensions available on request.

Non-tolerated dimensions ±1 mm

- 1) Check motor shaft fit.
- 2) Min./Max. permissible motor shaft length. Longer motor shafts are adaptable, please contact us.
- 3) The dimensions depend on the motor.
- 4) Smaller motor shaft diameter is compensated by a bushing with a minimum thickness of 1 mm.

CAD data is available under [www.wittenstein-alpha.com](http://www.wittenstein-alpha.com)

Motor mounting according to operating manual

SPK+

# SPK+ 140 MF 2-stage

		2-stage												
Ratio <sup>a)</sup>	<i>i</i>		12	16	20	25	28	35	40	50	70	100		
Max. acceleration torque (max. 1000 cycles per hour)	$T_{2B}$	Nm	600	600	600	600	600	600	500	600	600	480		
		in.lb	5310	5310	5310	5310	5310	5310	4425	5310	5310	4248		
Nominal output torque (with $n_m$ )	$T_{2N}$	Nm	360	360	360	360	360	360	320	360	360	220		
		in.lb	3186	3186	3186	3186	3186	3186	2832	3186	3186	1947		
Emergency stop torque (permitted 1000 times during the service life of the gearhead)	$T_{2Not}$	Nm	1000	1000	1250	1250	1250	1250	1000	1250	1250	1000		
		in.lb	8850	8850	11063	11063	11063	11063	8850	11063	11063	8850		
Nominal input speed (with $T_{2N}$ and 20°C ambient temperature) <sup>b), c)</sup>	$n_{1N}$	rpm	1900	2300	2300	2600	2300	2300	2300	2300	2300	2300		
Max. continuous speed (with 20% $T_{2N}$ and 20°C ambient temperature)	$n_{1Ncym}$	rpm	2700	3100	3100	3500	3100	3000	3000	3000	3000	3000		
Max. input speed	$n_{1Max}$	rpm	4500	4500	4500	4500	4500	4500	4500	4500	4500	4500		
Mean no load running torque (with $n_1=3000$ rpm and 20°C gearhead temperature) <sup>d)</sup>	$T_{01/2}$	Nm	4.0	3.7	3.6	2.8	3.5	3.9	3.1	3.1	3.1	3.1		
		in.lb	35.4	32.7	31.9	24.8	31	34.5	27.4	27.4	27.4	27.4		
Max. torsional backlash	$j_t$	arcmin	Standard $\leq 4$ / Reduced $\leq 2$											
Torsional rigidity	$C_{t21}$	Nm/ arcmin	53											
		in.lb/ arcmin	469											
Max. axial force <sup>e)</sup>	$F_{2AMax}$	N	9870											
		lb <sub>f</sub>	2221											
Max. radial force <sup>e)</sup>	$F_{2RMax}$	N	9450											
		lb <sub>f</sub>	2126											
Max. tilting moment	$M_{2KMax}$	Nm	952											
		in.lb	8425											
Efficiency at full load	$\eta$	%	94											
Service life (For calculation, see the Chapter "Information")	$L_h$	h	> 20000											
Weight incl. standard adapter plate	<i>m</i>	kg	20											
		lb <sub>m</sub>	44											
Operating noise (with $n_1=3000$ rpm no load)	$L_{PA}$	dB(A)	$\leq 68$											
Max. permitted housing temperature	°C		+90											
	F		194											
Ambient temperature	°C		0 to +40											
	F		32 to 104											
Lubrication	Lubricated for life													
Paint	Blue RAL 5002													
Direction of rotation	Motor and gearhead opposite directions													
Protection class	IP 65													
Moment of inertia (relates to the drive) Clamping hub diameter [mm]	H	28	$J_1$	kgcm <sup>2</sup>	4.68	3.82	3.75	3.31	3.68	2.97	2.80	2.79	2.78	2.77
				10 <sup>-3</sup> in.lb.s <sup>2</sup>	4.14	3.38	3.32	2.93	3.26	2.63	2.48	2.47	2.46	2.45
	K	38	$J_1$	kgcm <sup>2</sup>	11.8	11.0	10.9	10.5	10.9	10.1	9.96	9.95	9.94	9.94
				10 <sup>-3</sup> in.lb.s <sup>2</sup>	10.5	9.73	9.66	9.27	9.60	8.97	8.82	8.81	8.80	8.79

<sup>a)</sup> Other ratios up to  $i=1000$  available on request

<sup>b)</sup> Higher speeds are possible if the nominal torque is reduced

<sup>c)</sup> For higher ambient temperatures, please reduce input speed

<sup>d)</sup> Idling torques decrease during operation

<sup>e)</sup> Refers to center of the output shaft or flange

All technical data for front output side applies.

Technical data for rearward output versions, see page 386.

Please contact us for information on the best configuration for S1 conditions of use (continuous operation).

View A

2-stage:

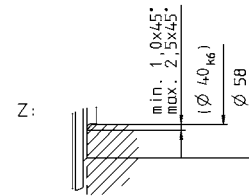
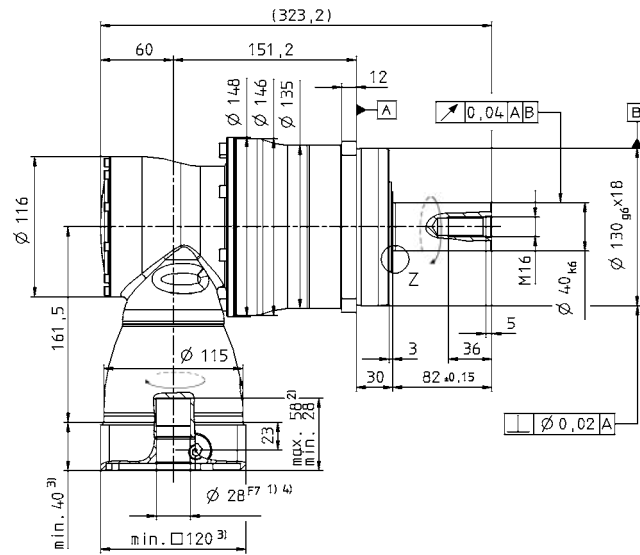
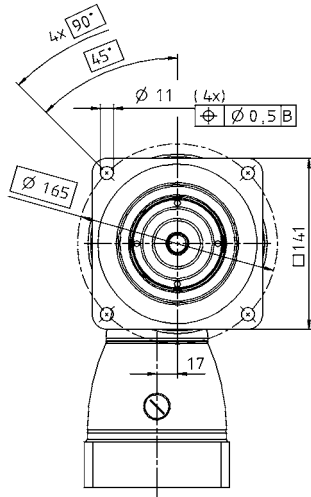

Right-angle gearheads  
High End

Alternatives: Output shaft variants

Keywayed output shaft in mm  
E = key as per DIN 6885, sheet 1, form A

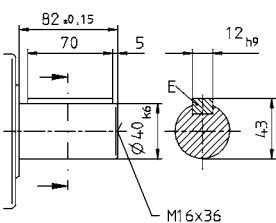

Involute gearing DIN 5480 in mm  
X = W 40 x 2 x 30 x 18 x 6m, DIN 5480

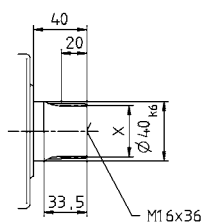

Shaft mounted  
Mounted via shrink disc

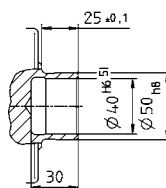

See technical data sheet for available clamping hub diameters (mass moment of inertia). Dimensions available on request.

Non-tolerated dimensions ±1 mm

- 1) Check motor shaft fit.
- 2) Min./Max. permissible motor shaft length. Longer motor shafts are adaptable, please contact us.
- 3) The dimensions depend on the motor.
- 4) Smaller motor shaft diameter is compensated by a bushing with a minimum thickness of 1 mm.

CAD data is available under [www.wittenstein-alpha.com](http://www.wittenstein-alpha.com)

Motor mounting according to operating manual

SPK+

# SPK+ 140 MF 3-stage

		3-stage															
Ratio <sup>a)</sup>		<i>i</i>	64	84	100	125	140	175	200	250	280	350	400	500	700	1000	
Max. acceleration torque (max. 1000 cycles per hour)	$T_{2B}$	Nm	600	600	600	600	600	600	600	600	600	600	500	600	600	480	
		in.lb	5310	5310	5310	5310	5310	5310	5310	5310	5310	5310	4425	5310	5310	4248	
Nominal output torque (with $n_n$ )	$T_{2N}$	Nm	360	360	360	360	360	360	360	360	360	360	320	360	360	220	
		in.lb	3186	3186	3186	3186	3186	3186	3186	3186	3186	3186	2832	3186	3186	1947	
Emergency stop torque (permitted 1000 times during the service life of the gearhead)	$T_{2Not}$	Nm	1000	1000	1250	1250	1250	1250	1250	1250	1250	1250	1000	1250	1250	1000	
		in.lb	8850	8850	11063	11063	11063	11063	11063	11063	11063	11063	8850	11063	11063	8850	
Nominal input speed (with $T_{2N}$ and 20°C ambient temperature) <sup>b), c)</sup>	$n_{1N}$	rpm	3100	3100	3100	3100	3100	3100	3100	3500	3100	3500	4200	4200	4200	4200	
Max. continuous speed (with 20% $T_{2N}$ and 20°C ambient temperature)	$n_{1Ncym}$	rpm	4000	4000	4000	4000	4000	4000	4000	4000	4000	4000	4200	4200	4200	4200	
Max. input speed	$n_{1Max}$	rpm	4500	4500	4500	4500	4500	4500	4500	4500	4500	4500	4500	4500	4500	4500	
Mean no load running torque (with $n_1=3000$ rpm and 20°C gearhead temperature) <sup>d)</sup>	$T_{0/2}$	Nm	0.7	0.4	0.6	0.5	0.5	0.4	0.3	0.3	0.3	0.3	0.3	0.3	0.3	0.3	
		in.lb	6.2	3.5	5.3	4.4	4.4	3.5	2.7	2.7	2.7	2.7	2.7	2.7	2.7	2.7	
Max. torsional backlash	$j_t$	arcmin	Standard $\leq 4$ / Reduced $\leq 2$														
Torsional rigidity	$C_{t21}$	Nm/arcmin	53														
		in.lb/arcmin	469														
Max. axial force <sup>e)</sup>	$F_{2AMax}$	N	9870														
		lb <sub>f</sub>	2221														
Max. radial force <sup>e)</sup>	$F_{2RMax}$	N	9450														
		lb <sub>f</sub>	2126														
Max. tilting moment	$M_{2KMax}$	Nm	952														
		in.lb	8425														
Efficiency at full load	$\eta$	%	92														
Service life (For calculation, see the Chapter "Information")	$L_h$	h	> 20000														
Weight incl. standard adapter plate	$m$	kg	20.7														
		lb <sub>m</sub>	45.7														
Operating noise (with $n_1=3000$ rpm no load)	$L_{PA}$	dB(A)	< 68														
Max. permitted housing temperature		°C	+90														
		F	194														
Ambient temperature		°C	0 to +40														
		F	32 to 104														
Lubrication			Lubricated for life														
Paint			Blue RAL 5002														
Direction of rotation			Motor and gearhead opposite directions														
Protection class			IP 65														
Moment of inertia (relates to the drive) Clamping hub diameter [mm]	E	19	$J_t$	kgcm <sup>2</sup>	1.01	0.76	0.88	0.85	0.76	0.75	0.70	0.69	0.70	0.69	0.69	0.69	0.69
				10 <sup>-3</sup> in.lb.s <sup>2</sup>	0.89	0.67	0.78	0.75	0.67	0.66	0.62	0.61	0.62	0.61	0.61	0.61	0.61
	G	24	$J_t$	kgcm <sup>2</sup>	2.57	2.32	2.44	2.42	2.32	2.31	2.26	2.25	2.26	2.25	2.25	2.25	2.25
				10 <sup>-3</sup> in.lb.s <sup>2</sup>	2.27	2.05	2.16	2.14	2.05	2.04	2.00	1.99	2.00	1.99	1.99	1.99	1.99

<sup>a)</sup> Other ratios up to  $i=1000$  available on request

<sup>b)</sup> Higher speeds are possible if the nominal torque is reduced

<sup>c)</sup> For higher ambient temperatures, please reduce input speed

<sup>d)</sup> Idling torques decrease during operation

<sup>e)</sup> Refers to center of the output shaft or flange

All technical data for front output side applies.

Technical data for rearward output versions, see page 386.

Please contact us for information on the best configuration for S1 conditions of use (continuous operation).

View A

3-stage:

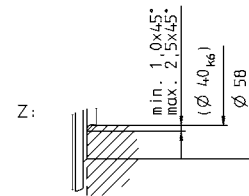
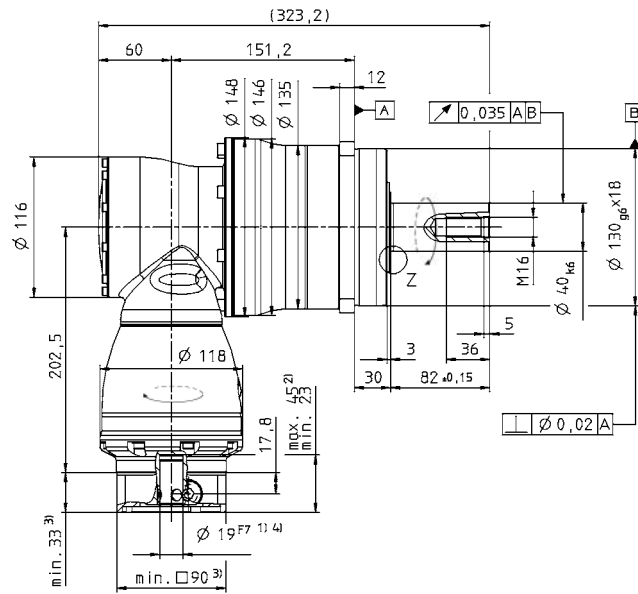
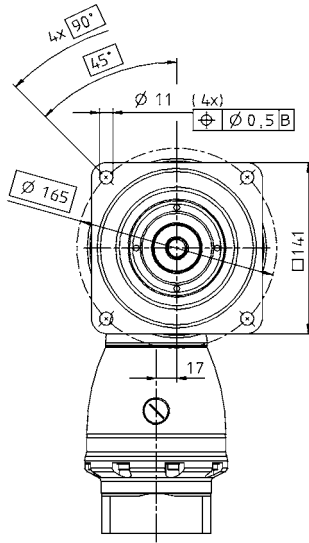

Right-angle gearheads  
High End

Alternatives: Output shaft variants

Keywayed output shaft in mm  
E = key as per DIN 6885, sheet 1, form A

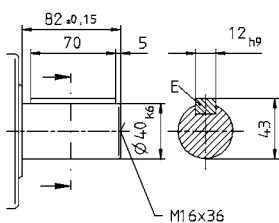

Involute gearing DIN 5480 in mm  
X = W 40 x 2 x 30 x 18 x 6m, DIN 5480

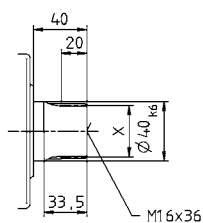

Shaft mounted  
Mounted via shrink disc

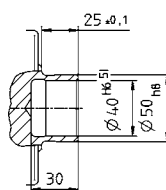

See technical data sheet for available clamping hub diameters (mass moment of inertia). Dimensions available on request.

Non-tolerated dimensions ±1 mm

- 1) Check motor shaft fit.
- 2) Min./Max. permissible motor shaft length. Longer motor shafts are adaptable, please contact us.
- 3) The dimensions depend on the motor.
- 4) Smaller motor shaft diameter is compensated by a bushing with a minimum thickness of 1 mm.

CAD data is available under [www.wittenstein-alpha.com](http://www.wittenstein-alpha.com)

Motor mounting according to operating manual

SPK+



# SPK+ 180 MF 2-stage

		2-stage												
Ratio <sup>a)</sup>	<i>i</i>		12	16	20	25	28	35	40	50	70	100		
Max. acceleration torque (max. 1000 cycles per hour)	$T_{2B}$	Nm	1100	1100	1100	1100	1100	1100	840	1050	1100	880		
		in.lb	9735	9735	9735	9735	9735	9735	7434	9293	9735	7788		
Nominal output torque (with $n_m$ )	$T_{2N}$	Nm	750	750	750	750	750	750	640	750	750	750		
		in.lb	6638	6638	6638	6638	6638	6638	5664	6638	6638	6638		
Emergency stop torque (permitted 1000 times during the service life of the gearhead)	$T_{2Not}$	Nm	1600	1600	2000	2000	2750	2000	1600	2000	2750	2200		
		in.lb	14160	14160	17700	17700	24338	17700	14160	17700	24338	19470		
Nominal input speed (with $T_{2N}$ and 20°C ambient temperature) <sup>b), c)</sup>	$n_{1N}$	rpm	1600	1900	1900	2100	1900	2100	2100	2100	2100	2100		
Max. continuous speed (with 20% $T_{2N}$ and 20°C ambient temperature)	$n_{1Ncym}$	rpm	2300	2600	2600	2800	2600	3000	3000	3000	3000	3000		
Max. input speed	$n_{1Max}$	rpm	4500	4500	4500	4500	4500	4500	4500	4500	4500	4500		
Mean no load running torque (with $n_1=3000$ rpm and 20°C gearhead temperature) <sup>d)</sup>	$T_{012}$	Nm	9.0	6.5	6.5	5.5	6.0	8.0	6.0	6.0	6.0	6.0		
		in.lb	79.7	57.5	57.5	48.7	53.1	70.8	53.1	53.1	53.1	53.1		
Max. torsional backlash	$j_t$	arcmin	Standard $\leq 4$ / Reduced $\leq 2$											
Torsional rigidity	$C_{t21}$	Nm/ arcmin	175											
		in.lb/ arcmin	1549											
Max. axial force <sup>e)</sup>	$F_{2AMax}$	N	14150											
		lb <sub>f</sub>	3184											
Max. radial force <sup>e)</sup>	$F_{2RMax}$	N	14700											
		lb <sub>f</sub>	3308											
Max. tilting moment	$M_{2KMax}$	Nm	1600											
		in.lb	14160											
Efficiency at full load	$\eta$	%	94											
Service life (For calculation, see the Chapter "Information")	$L_h$	h	> 20000											
Weight incl. standard adapter plate	<i>m</i>	kg	45											
		lb <sub>m</sub>	99											
Operating noise (with $n_1=3000$ rpm no load)	$L_{PA}$	dB(A)	$\leq 70$											
Max. permitted housing temperature		°C	+90											
		F	194											
Ambient temperature		°C	0 to +40											
		F	32 to 104											
Lubrication			Lubricated for life											
Paint			Blue RAL 5002											
Direction of rotation			Motor and gearhead opposite directions											
Protection class			IP 65											
Moment of inertia (relates to the drive) Clamping hub diameter [mm]	K	38	$J_t$	kgcm <sup>2</sup>	24.7	19.5	19.0	16.3	18.6	14.0	12.9	12.8	12.7	12.7
				10 <sup>-1</sup> in.lb. <sup>2</sup>	21.9	17.2	16.8	14.4	16.5	12.4	11.4	11.3	11.3	11.2

<sup>a)</sup> Other ratios up to  $i=1000$  available on request

<sup>b)</sup> Higher speeds are possible if the nominal torque is reduced

<sup>c)</sup> For higher ambient temperatures, please reduce input speed

<sup>d)</sup> Idling torques decrease during operation

<sup>e)</sup> Refers to center of the output shaft or flange

All technical data for front output side applies.

Technical data for rearward output versions, see page 386.

Please contact us for information on the best configuration for S1 conditions of use (continuous operation).

View A

2-stage:

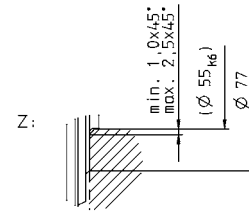
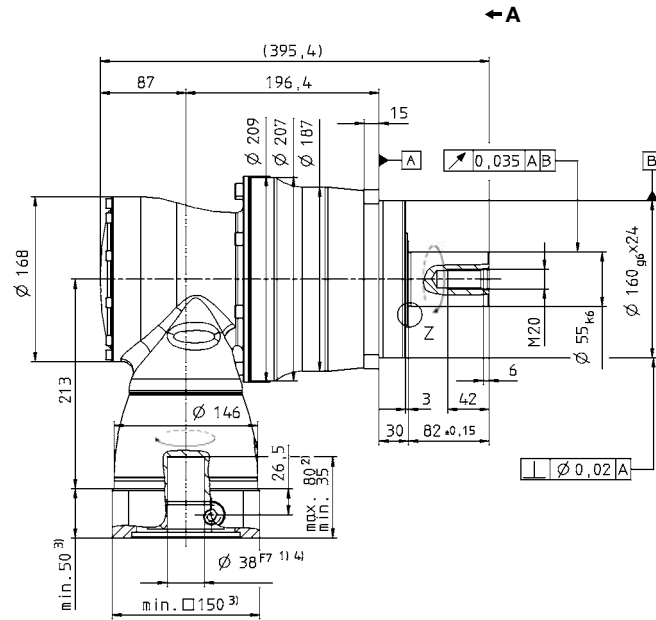
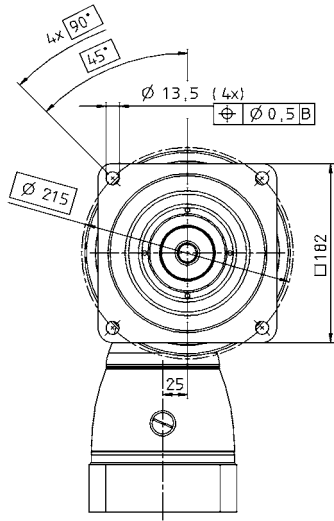

Right-angle gearheads  
High End

Alternatives: Output shaft variants

Keywayed output shaft in mm  
E = key as per DIN 6885, sheet 1, form A

Involute gearing DIN 5480 in mm  
X = W 55 x 2 x 30 x 26 x 6m, DIN 5480

Shaft mounted  
Mounted via shrink disc

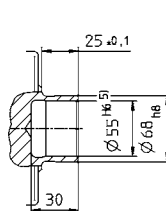
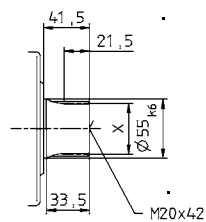
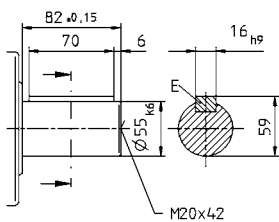

See technical data sheet for available clamping hub diameters (mass moment of inertia). Dimensions available on request.

Non-tolerated dimensions ±1 mm

- 1) Check motor shaft fit.
- 2) Min./Max. permissible motor shaft length. Longer motor shafts are adaptable, please contact us.
- 3) The dimensions depend on the motor.
- 4) Smaller motor shaft diameter is compensated by a bushing with a minimum thickness of 1 mm.

CAD data is available under [www.wittenstein-alpha.com](http://www.wittenstein-alpha.com)

Motor mounting according to operating manual

SPK+

# SPK+ 180 MF 3-stage

		3-stage															
Ratio <sup>a)</sup>		<i>i</i>	64	84	100	125	140	175	200	250	280	350	400	500	700	1000	
Max. acceleration torque (max. 1000 cycles per hour)	$T_{2B}$	Nm	1100	1100	1100	1100	1100	1100	1100	1100	1100	1100	840	1050	1100	880	
		in.lb	9735	9735	9735	9735	9735	9735	9735	9735	9735	9735	7434	9293	9735	7788	
Nominal output torque (with $n_m$ )	$T_{2N}$	Nm	750	750	750	750	750	750	750	750	750	750	640	750	750	750	
		in.lb	6638	6638	6638	6638	6638	6638	6638	6638	6638	6638	5664	6638	6638	6638	
Emergency stop torque (permitted 1000 times during the service life of the gearhead)	$T_{2Not}$	Nm	1600	1600	2000	2000	2000	2000	2000	2000	2000	2750	2000	1600	2000	2750	2200
		in.lb	14160	14160	17700	17700	17700	17700	17700	17700	17700	24338	17700	14160	17700	24338	19470
Nominal input speed (with $T_{2N}$ and 20°C ambient temperature) <sup>b), c)</sup>	$n_{1N}$	rpm	2900	2900	2900	2900	2900	2900	2900	3200	2900	3200	3900	3900	3900	3900	
Max. continuous speed (with 20% $T_{2N}$ and 20°C ambient temperature)	$n_{1Ncym}$	rpm	4000	4000	4000	4000	4000	4000	4000	4000	4000	4000	4200	4200	4200	4200	
Max. input speed	$n_{1Max}$	rpm	4500	4500	4500	4500	4500	4500	4500	4500	4500	4500	4500	4500	4500	4500	
Mean no load running torque (with $n_1=3000$ rpm and 20°C gearhead temperature) <sup>d)</sup>	$T_{01/2}$	Nm	1	0.5	0.8	0.6	0.6	0.5	0.5	0.4	0.5	0.4	0.4	0.4	0.4	0.4	
		in.lb	8.9	4.4	7.1	5.3	5.3	4.4	4.4	3.5	4.4	3.5	3.5	3.5	3.5	3.5	
Max. torsional backlash	$j_t$	arcmin	Standard $\leq 4$ / Reduced $\leq 2$														
Torsional rigidity	$C_{t21}$	Nm/ arcmin	175														
		in.lb/ arcmin	1549														
Max. axial force <sup>e)</sup>	$F_{2AMax}$	N	14150														
		lb <sub>f</sub>	3184														
Max. radial force <sup>e)</sup>	$F_{2RMax}$	N	14700														
		lb <sub>f</sub>	3308														
Max. tilting moment	$M_{2KMax}$	Nm	1600														
		in.lb	14160														
Efficiency at full load	$\eta$	%	92														
Service life (For calculation, see the Chapter "Information")	$L_h$	h	> 20000														
Weight incl. standard adapter plate	$m$	kg	47.4														
		lb <sub>m</sub>	104.8														
Operating noise (with $n_1=3000$ rpm no load)	$L_{PA}$	dB(A)	< 70														
Max. permitted housing temperature		°C	+90														
		F	194														
Ambient temperature		°C	0 to +40														
		F	32 to 104														
Lubrication			Lubricated for life														
Paint			Blue RAL 5002														
Direction of rotation			Motor and gearhead opposite directions														
Protection class			IP 65														
Moment of inertia (relates to the drive)	G	24	$J_1$	kgcm <sup>2</sup>	3.97	2.82	3.36	3.22	2.82	2.75	2.50	2.47	2.50	2.44	2.42	2.42	2.42
				10 <sup>3</sup> in.lb.s <sup>2</sup>	3.51	2.50	2.97	2.85	2.50	2.43	2.21	2.19	2.21	2.16	2.14	2.14	2.14
Clamping hub diameter [mm]	K	38	$J_1$	kgcm <sup>2</sup>	10.90	9.74	10.30	10.10	9.74	9.66	9.41	9.38	9.41	9.38	9.33	9.33	9.33
				10 <sup>3</sup> in.lb.s <sup>2</sup>	9.65	8.62	9.12	8.94	8.62	8.55	8.33	8.30	8.33	8.30	8.26	8.26	8.26

<sup>a)</sup> Other ratios up to  $i=1000$  available on request

<sup>b)</sup> Higher speeds are possible if the nominal torque is reduced

<sup>c)</sup> For higher ambient temperatures, please reduce input speed

<sup>d)</sup> Idling torques decrease during operation

<sup>e)</sup> Refers to center of the output shaft or flange

All technical data for front output side applies.

Technical data for rearward output versions, see page 386.

Please contact us for information on the best configuration for S1 conditions of use (continuous operation).

View A

3-stage:

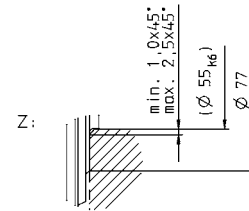
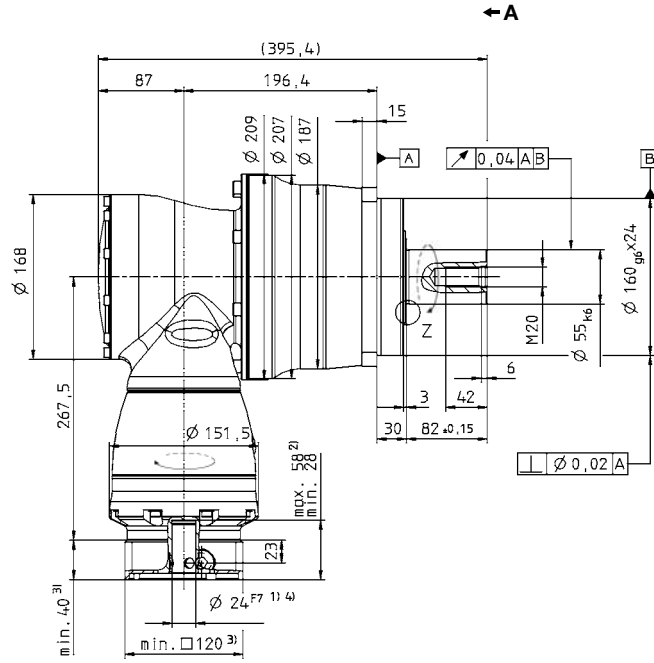
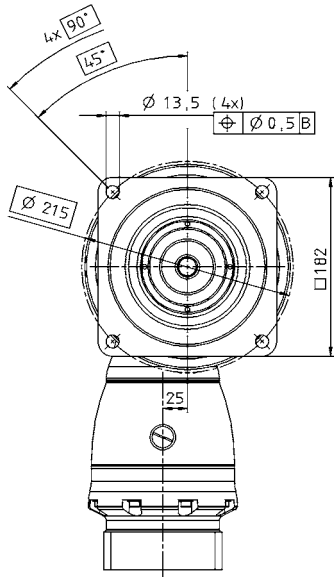

Right-angle gearheads  
High End

Alternatives: Output shaft variants

Keywayed output shaft in mm  
E = key as per DIN 6885, sheet 1, form A

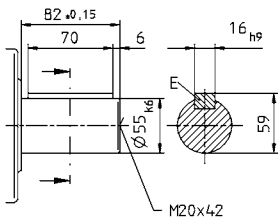

Involute gearing DIN 5480 in mm  
X = W 55 x 2 x 30 x 26 x 6m, DIN 5480

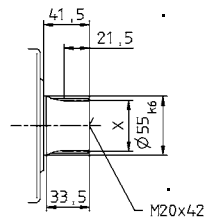

Shaft mounted  
Mounted via shrink disc

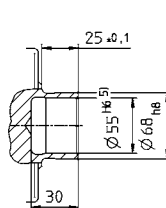

See technical data sheet for available clamping hub diameters (mass moment of inertia). Dimensions available on request.

Non-tolerated dimensions ±1 mm

- 1) Check motor shaft fit.
- 2) Min./Max. permissible motor shaft length. Longer motor shafts are adaptable, please contact us.
- 3) The dimensions depend on the motor.
- 4) Smaller motor shaft diameter is compensated by a bushing with a minimum thickness of 1 mm.

CAD data is available under [www.wittenstein-alpha.com](http://www.wittenstein-alpha.com)

Motor mounting according to operating manual

SPK+

# SPK+ 210 MF 2-stage

		2-stage												
Ratio <sup>a)</sup>	<i>i</i>		12	16	20	25	28	35	40	50	70	100		
Max. acceleration torque (max. 1000 cycles per hour)	$T_{2B}$	Nm	2500	2500	2500	2500	2400	2400	1850	2300	2400	1900		
		in.lb	22125	22125	22125	22125	21240	21240	16373	20355	21240	16815		
Nominal output torque (with $n_m$ )	$T_{2N}$	Nm	1500	1500	1500	1500	1400	1500	1400	1500	1400	1000		
		in.lb	13.275	13275	13275	13275	12390	13275	12390	13275	12390	8850		
Emergency stop torque (permitted 1000 times during the service life of the gearhead)	$T_{2Not}$	Nm	3600	4200	5200	5200	5200	5200	3600	4500	5200	5000		
		in.lb	31860	37170	46020	46020	46020	46020	31860	39825	46020	44250		
Nominal input speed (with $T_{2N}$ and 20°C ambient temperature) <sup>b), c)</sup>	$n_{1N}$	rpm	1500	1700	1700	1900	1700	1900	1700	1700	1700	1700		
Max. continuous speed (with 20% $T_{2N}$ and 20°C ambient temperature)	$n_{1Ncym}$	rpm	1900	2300	2300	2700	2300	2700	2400	2400	2400	2400		
Max. input speed	$n_{1Max}$	rpm	4000	4000	4000	4000	4000	4000	4000	4000	4000	4000		
Mean no load running torque (with $n_1=3000$ rpm and 20°C gearhead temperature) <sup>d)</sup>	$T_{012}$	Nm	18.5	17.0	15.0	13.0	14.0	12.0	15.0	15.0	14.0	13.0		
		in.lb	163.7	150.5	132.8	115.1	123.9	106.2	132.8	132.8	123.9	115.1		
Max. torsional backlash	$j_t$	arcmin	Standard $\leq 4$ / Reduced $\leq 2$											
Torsional rigidity	$C_{t21}$	Nm/arcmin	300	300	300	300	300	300	300	300	300	300		
		in.lb/arcmin	2.655	2.655	2.655	2.655	2.655	2.655	2.655	2.655	2.655	2.655		
Max. axial force <sup>e)</sup>	$F_{2AMax}$	N	30000											
		lb <sub>f</sub>	6750											
Max. radial force <sup>e)</sup>	$F_{2RMax}$	N	21000											
		lb <sub>f</sub>	4725											
Max. tilting moment	$M_{2KMax}$	Nm	3100											
		in.lb	27435											
Efficiency at full load	$\eta$	%	94											
Service life (For calculation, see the Chapter "Information")	$L_h$	h	> 20000											
Weight incl. standard adapter plate	<i>m</i>	kg	82											
		lb <sub>m</sub>	181											
Operating noise (with $n_1=3000$ rpm no load)	$L_{PA}$	dB(A)	$\leq 71$											
Max. permitted housing temperature		°C	+90											
		F	194											
Ambient temperature		°C	0 to +40											
		F	32 to 104											
Lubrication	Lubricated for life													
Paint	Blue RAL 5002													
Direction of rotation	Motor and gearhead opposite directions													
Protection class	IP 65													
Moment of inertia (relates to the drive) Clamping hub diameter [mm]	M	48	$J_1$	kgcm <sup>2</sup>	78.80	54.60	53.00	43.40	51.50	42.20	30.20	30.00	29.80	29.80
				10 <sup>-3</sup> in.lb.s <sup>2</sup>	69.74	48.32	46.91	38.41	45.58	37.35	26.73	26.55	26.37	26.37

<sup>a)</sup> Other ratios available on request

<sup>b)</sup> Higher speeds are possible if the nominal torque is reduced

<sup>c)</sup> For higher ambient temperatures, please reduce input speed

<sup>d)</sup> Idling torques decrease during operation

<sup>e)</sup> Refers to center of the output shaft or flange

All technical data for front output side applies.

Technical data for rearward output versions, see page 386.

Please contact us for information on the best configuration for S1 conditions of use (continuous operation).

View A

2-stage:

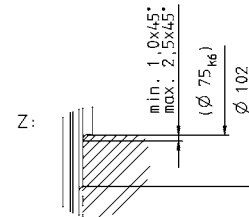
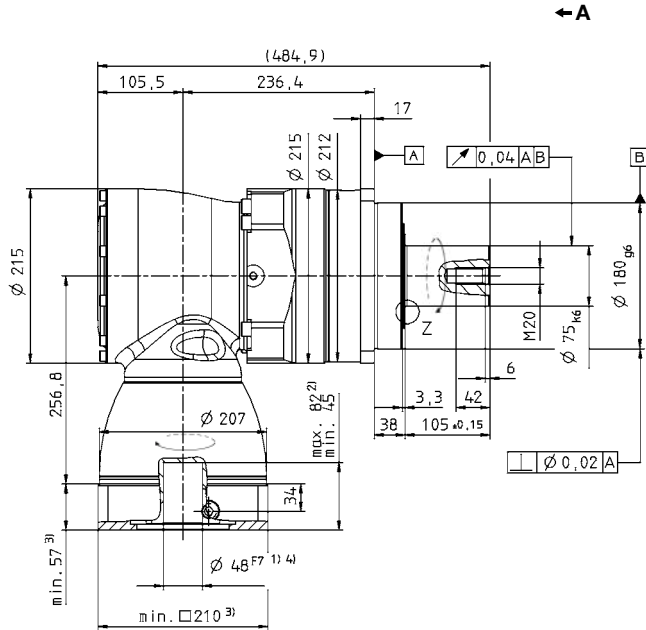
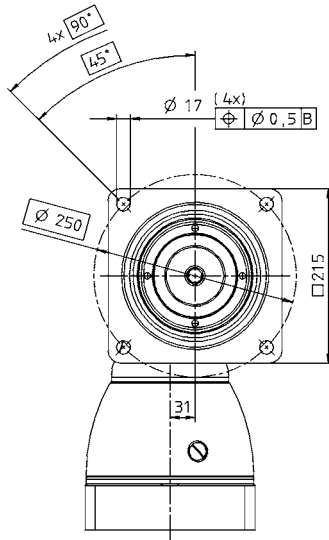

Right-angle gearheads  
High End

Alternatives: Output shaft variants

Keywayed output shaft in mm  
E = key as per DIN 6885, sheet 1, form A

Involute gearing DIN 5480 in mm  
X = W 70 x 2 x 30 x 34 x 6m, DIN 5480

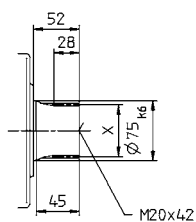
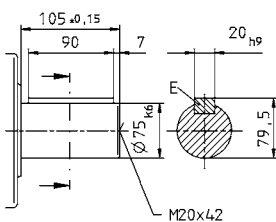

See technical data sheet for available clamping hub diameters (mass moment of inertia). Dimensions available on request.

Non-tolerated dimensions ±1 mm

- 1) Check motor shaft fit.
- 2) Min./Max. permissible motor shaft length. Longer motor shafts are adaptable, please contact us.
- 3) The dimensions depend on the motor.
- 4) Smaller motor shaft diameter is compensated by a bushing with a minimum thickness of 1 mm.

CAD data is available under [www.wittenstein-alpha.com](http://www.wittenstein-alpha.com)

Motor mounting according to operating manual

SPK+

# SPK+ 210 MF 3-stage

		3-stage															
Ratio <sup>a)</sup>		<i>i</i>	64	84	100	125	140	175	200	250	280	350	400	500	700	1000	
Max. acceleration torque (max. 1000 cycles per hour)	$T_{2B}$	Nm	2400	2400	2500	2500	2500	2500	2500	2500	2400	2400	1900	2350	2400	1900	
		in.lb	21240	21240	22125	22125	22125	22125	22125	22125	21240	21240	16815	20798	21240	16815	
Nominal output torque (with $n_m$ )	$T_{2N}$	Nm	1500	1500	1500	1500	1500	1500	1500	1500	1400	1400	1500	1500	1400	1000	
		in.lb	13275	13275	13275	13275	13275	13275	13275	13275	12390	12390	13275	13275	12390	8850	
Emergency stop torque (permitted 1000 times during the service life of the gearhead)	$T_{2Not}$	Nm	4200	3600	5200	5200	5200	5200	5200	5200	5200	5200	3600	4500	5200	5000	
		in.lb	37170	31860	46020	46020	46020	46020	46020	46020	46020	46020	31860	39825	46020	44250	
Nominal input speed (with $T_{2N}$ and 20°C ambient temperature) <sup>b), c)</sup>	$n_{1N}$	rpm	2700	2700	2700	2700	2700	2700	2700	2900	2700	2900	3400	3400	3400	3400	
Max. continuous speed (with 20% $T_{2N}$ and 20°C ambient temperature)	$n_{1Ncym}$	rpm	3500	3500	3500	3500	3500	3500	3500	3500	3500	3500	3500	3500	3800	3800	
Max. input speed	$n_{1Max}$	rpm	4000	4000	4000	4000	4000	4000	4000	4000	4000	4000	4000	4000	4000	4000	
Mean no load running torque (with $n_1=3000$ rpm and 20°C gearhead temperature) <sup>d)</sup>	$T_{012}$	Nm	2.4	1.2	1.9	1.7	1.3	1.3	1.0	1.0	1.0	1.0	1.0	1.0	1.0	1.0	
		in.lb	21.2	10.6	16.8	15.0	11.5	11.5	8.9	8.9	8.9	8.9	8.9	8.9	8.9	8.9	
Max. torsional backlash	$j_t$	arcmin	Standard $\leq 4$ / Reduced $\leq 2$														
Torsional rigidity	$C_{t21}$	Nm/arcmin	300	300	300	300	300	300	300	300	300	300	300	300	300	300	
		in.lb/arcmin	2.655	2.655	2.655	2.655	2.655	2.655	2.655	2.655	2.655	2.655	2.655	2.655	2.655	2.655	
Max. axial force <sup>e)</sup>	$F_{2AMax}$	N	30000														
		lb <sub>f</sub>	6750														
Max. radial force <sup>e)</sup>	$F_{2RMax}$	N	21000														
		lb <sub>f</sub>	4725														
Max. tilting moment	$M_{2KMax}$	Nm	3100														
		in.lb	27435														
Efficiency at full load	$\eta$	%	92														
Service life (For calculation, see the Chapter "Information")	$L_h$	h	> 20000														
Weight incl. standard adapter plate	<i>m</i>	kg	86														
		lb <sub>m</sub>	190														
Operating noise (with $n_1=3000$ rpm no load)	$L_{PA}$	dB(A)	$\leq 71$														
Max. permitted housing temperature		°C	+90														
		F	194														
Ambient temperature		°C	0 to +40														
		F	32 to 104														
Lubrication			Lubricated for life														
Paint			Blue RAL 5002														
Direction of rotation			Motor and gearhead opposite directions														
Protection class			IP 65														
Moment of inertia (relates to the drive) Clamping hub diameter [mm]	K 38	$J_1$	kgcm <sup>2</sup>	14.00	10.90	12.30	12.00	10.90	10.70	10.10	10.00	10.10	10.00	9.90	9.90	9.90	9.90
			10 <sup>3</sup> in.lb.in <sup>2</sup>	12.39	9.65	10.89	10.62	9.65	9.47	8.94	8.85	8.94	8.85	8.76	8.76	8.76	8.76
	M 48	$J_1$	kgcm <sup>2</sup>	28.70	25.60	27.10	26.70	26.70	25.60	24.80	24.70	24.80	24.70	24.60	24.60	24.60	24.60
			10 <sup>3</sup> in.lb.in <sup>2</sup>	25.40	22.66	23.98	23.63	23.63	22.66	21.95	21.86	21.95	21.86	21.77	21.77	21.77	21.77

<sup>a)</sup> Other ratios available on request

<sup>b)</sup> Higher speeds are possible if the nominal torque is reduced

<sup>c)</sup> For higher ambient temperatures, please reduce input speed

<sup>d)</sup> Idling torques decrease during operation

<sup>e)</sup> Refers to center of the output shaft or flange

All technical data for front output side applies.

Technical data for rearward output versions, see page 386.

Please contact us for information on the best configuration for S1 conditions of use (continuous operation).

View A

3-stage:

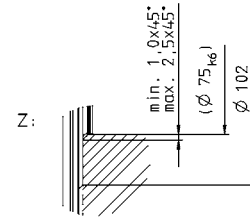
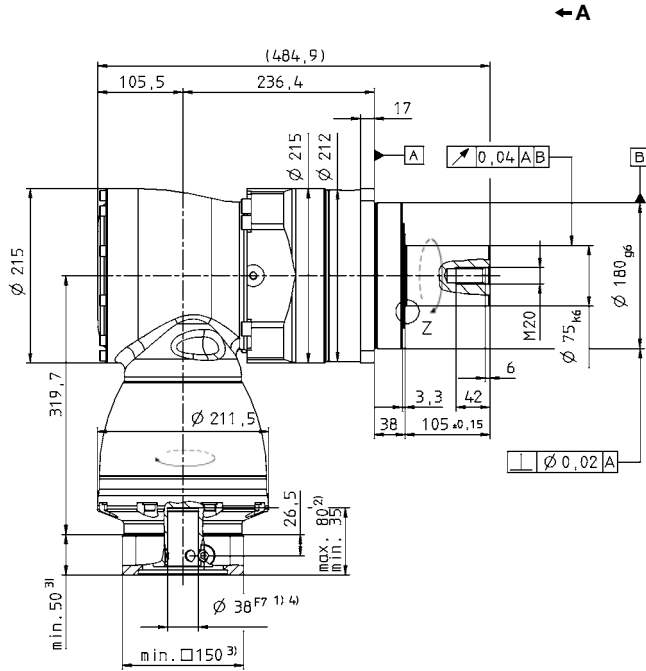
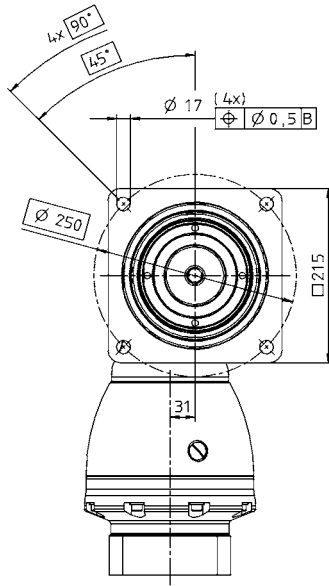

Right-angle gearheads  
High End

Alternatives: Output shaft variants

Keywayed output shaft in mm  
E = key as per DIN 6885, sheet 1, form A

Involute gearing DIN 5480 in mm  
X = W 70 x 2 x 30 x 34 x 6m, DIN 5480

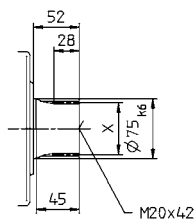
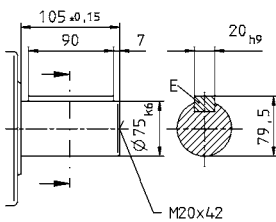

See technical data sheet for available clamping hub diameters (mass moment of inertia). Dimensions available on request.

Non-tolerated dimensions ±1 mm

- 1) Check motor shaft fit.
- 2) Min./Max. permissible motor shaft length. Longer motor shafts are adaptable, please contact us.
- 3) The dimensions depend on the motor.
- 4) Smaller motor shaft diameter is compensated by a bushing with a minimum thickness of 1 mm.

CAD data is available under [www.wittenstein-alpha.com](http://www.wittenstein-alpha.com)

Motor mounting according to operating manual

SPK+



# SPK+ 240 MF 3-stage

		3-stage															
Ratio <sup>a)</sup>	<i>i</i>	48	64	100	125	140	175	200	250	280	350	400	500	700	1000		
Max. acceleration torque (max. 1000 cycles per hour)	$T_{2B}$	Nm	4500	4500	4500	4500	4500	4500	4500	4500	4300	4500	4000	4300	4300	3400	
		in.lb	39825	39825	39825	39825	39825	39825	39825	39825	38055	39825	35400	38055	38055	30090	
Nominal output torque (with $n_m$ )	$T_{2N}$	Nm	2500	2500	2500	2500	2500	2500	2500	2300	2500	2500	2500	2300	2300	1700	
		in.lb	22125	22125	22125	22125	22125	22125	22125	20355	22125	22125	22125	20355	20355	15045	
Emergency stop torque (permitted 1000 times during the service life of the gearhead)	$T_{2Not}$	Nm	6400	8000	8500	8500	8500	8500	8500	8500	8500	8500	8500	8500	8500	6800	
		in.lb	56640	70800	75225	75225	75225	75225	75225	75225	75225	75225	75225	75225	75225	60180	
Nominal input speed (with $T_{2N}$ and 20°C ambient temperature) <sup>b), c)</sup>	$n_{1N}$	rpm	1800	1900	1900	2100	1900	2100	2100	2100	2100	2100	2100	2100	2100	2100	
Max. continuous speed (with 20% $T_{2N}$ and 20°C ambient temperature)	$n_{1Ncym}$	rpm	2000	2200	2600	2600	2300	2300	2300	2300	2300	2300	2300	2300	2300	2300	
Max. input speed	$n_{1Max}$	rpm	4500	4500	4500	4500	4500	4500	4500	4500	4500	4500	4500	4500	4500	4500	
Mean no load running torque (with $n_1=3000$ rpm and 20°C gearhead temperature) <sup>d)</sup>	$T_{012}$	Nm	11.0	8.0	7.0	7.0	8.0	8.0	7.0	6.0	6.0	6.0	6.0	6.0	6.0	6.0	
		in.lb	94.3	70.8	62.0	62.0	70.8	70.8	62.0	53.1	53.1	53.1	53.1	53.1	53.1	53.1	
Max. torsional backlash	$j_t$	arcmin	Standard $\leq 5,5$ / Reduced $\leq 3,5$														
Torsional rigidity	$C_{t21}$	Nm/arcmin	510	510	510	510	510	510	510	510	510	510	510	510	510	510	
		in.lb/arcmin	4.514	4.514	4.514	4.514	4.514	4.514	4.514	4.514	4.514	4.514	4.514	4.514	4.514	4.514	
Max. axial force <sup>e)</sup>	$F_{2AMax}$	N	33000														
		lb <sub>f</sub>	7425														
Max. radial force <sup>e)</sup>	$F_{2RMax}$	N	30000														
		lb <sub>f</sub>	6750														
Max. tilting moment	$M_{2KMax}$	Nm	5000														
		in.lb	44250														
Efficiency at full load	$\eta$	%	92														
Service life (For calculation, see the Chapter "Information")	$L_h$	h	> 20000														
Weight incl. standard adapter plate	<i>m</i>	kg	93														
		lb <sub>m</sub>	206														
Operating noise (with $n_1=3000$ rpm no load)	$L_{PA}$	dB(A)	$\leq 71$														
Max. permitted housing temperature		°C	+90														
		F	194														
Ambient temperature		°C	0 to +40														
		F	32 to 104														
Lubrication			Lubricated for life														
Paint			Blue RAL 5002														
Direction of rotation			Motor and gearhead opposite directions														
Protection class			IP 65														
Moment of inertia (relates to the drive) Clamping hub diameter [mm]	K	38	$J_1$	kgcm <sup>2</sup>	26.5	20.00	17.00	17.00	15.00	15.00	13.00	13.00	13.00	13.00	13.00	13.00	13.00
				10 <sup>-3</sup> in.lb.s <sup>2</sup>	23.40	17.70	15.05	15.05	13.28	13.28	11.51	11.51	11.51	11.51	11.51	11.51	11.51

<sup>a)</sup> Other ratios available on request

<sup>b)</sup> Higher speeds are possible if the nominal torque is reduced

<sup>c)</sup> For higher ambient temperatures, please reduce input speed

<sup>d)</sup> Idling torques decrease during operation

<sup>e)</sup> Refers to center of the output shaft or flange

All technical data for front output side applies.

Technical data for rearward output versions, see page 386.

Please contact us for information on the best configuration for S1 conditions of use (continuous operation).

View A

3-stage:

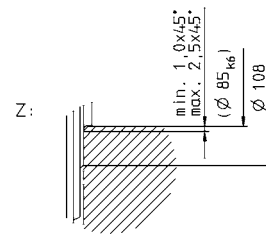
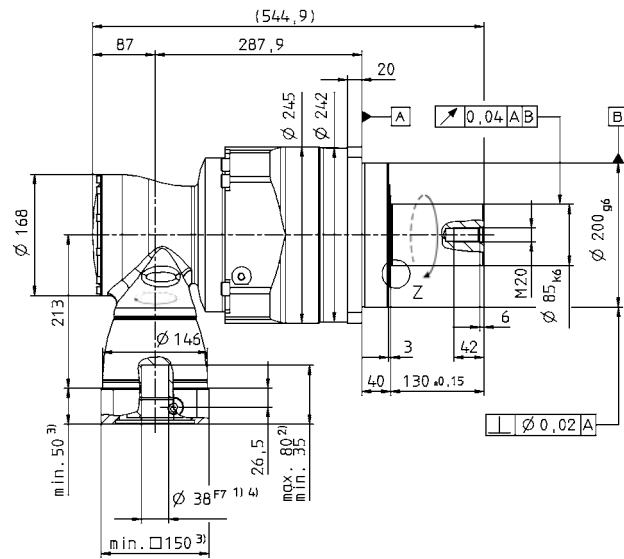
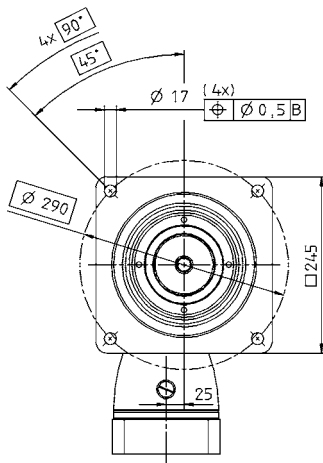

Alternatives: Output shaft variants

Keywayed output shaft in mm  
E = key as per DIN 6885, sheet 1, form A

Involute gearing DIN 5480 in mm  
X = W 80 x 2 x 30 x 38 x 6m, DIN 5480

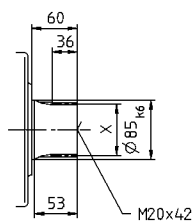
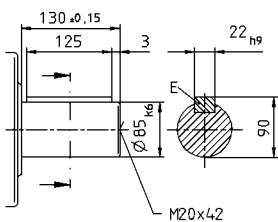

See technical data sheet for available clamping hub diameters (mass moment of inertia). Dimensions available on request.

Non-tolerated dimensions ±1 mm

- 1) Check motor shaft fit.
- 2) Min./Max. permissible motor shaft length. Longer motor shafts are adaptable, please contact us.
- 3) The dimensions depend on the motor.
- 4) Smaller motor shaft diameter is compensated by a bushing with a minimum thickness of 1 mm.

CAD data is available under [www.wittenstein-alpha.com](http://www.wittenstein-alpha.com)

Motor mounting according to operating manual

# SPK+ 240 MF 4-stage i=144-1000

		4-stage															
Ratio <sup>a)</sup>		<i>i</i>	144	192	256	300	375	420	500	560	600	700	800	875	1000		
Max. acceleration torque (max. 1000 cycles per hour)	$T_{2B}$	Nm	4500	4500	4500	4500	4500	4500	4500	4500	4500	4500	4500	4500	4500		
		in.lb	39825	39825	39825	39825	39825	39825	39825	39825	39825	39825	39825	39825	39825		
Nominal output torque (with $n_{in}$ )	$T_{2N}$	Nm	2500	2500	2500	2500	2500	2500	2500	2500	2500	2500	2500	2500	2500		
		in.lb	22125	22125	22125	22125	22125	22125	22125	22125	22125	22125	22125	22125	22125		
Emergency stop torque (permitted 1000 times during the service life of the gearhead)	$T_{2Not}$	Nm	8000	8000	8000	8500	8500	8500	8500	8500	8500	8500	8500	8500	8500		
		in.lb	70800	70800	70800	75225	75225	75225	75225	75225	75225	75225	75225	75225	75225		
Nominal input speed (with $T_{2N}$ and 20°C ambient temperature) <sup>b), c)</sup>	$n_{1N}$	rpm	2700	2900	2900	2900	2900	2900	2900	2900	2900	2900	2900	2900	3200		
Max. continuous speed (with 20% $T_{2N}$ and 20°C ambient temperature)	$n_{1Ncym}$	rpm	3800	4000	4000	4000	4000	4000	4000	4000	4000	4000	4000	4000	4200		
Max. input speed	$n_{1Max}$	rpm	4500	4500	4500	4500	4500	4500	4500	4500	4500	4500	4500	4500	4500		
Mean no load running torque (with $n_1=3000$ rpm and 20°C gearhead temperature) <sup>d)</sup>	$T_{012}$	Nm	3.2	2.3	1.6	1.3	0.7	0.9	0.9	0.8	0.7	0.7	0.6	0.6	0.5		
		in.lb	28.3	20.4	14.2	11.5	6.2	8.0	8.0	7.1	6.2	6.2	5.3	5.3	4.4		
Max. torsional backlash	$j_t$	arcmin	Standard $\leq 5,5$ / Reduced $\leq 3,5$														
Torsional rigidity	$C_{t21}$	Nm/arcmin	510	510	510	510	510	510	510	510	510	510	510	510	510		
		in.lb/arcmin	4.514	4.514	4.514	4.514	4.514	4.514	4.514	4.514	4.514	4.514	4.514	4.514	4.514		
Max. axial force <sup>e)</sup>	$F_{2AMax}$	N	33000														
		lb <sub>f</sub>	7425														
Max. radial force <sup>e)</sup>	$F_{2RMax}$	N	30000														
		lb <sub>f</sub>	6750														
Max. tilting moment	$M_{2KMax}$	Nm	5000														
		in.lb	44250														
Efficiency at full load	$\eta$	%	90														
Service life (For calculation, see the Chapter "Information")	$L_h$	h	> 20000														
Weight incl. standard adapter plate	$m$	kg	96														
		lb <sub>m</sub>	212														
Operating noise (with $n_1=3000$ rpm no load)	$L_{PA}$	dB(A)	$\leq 71$														
Max. permitted housing temperature		°C	+90														
		F	194														
Ambient temperature		°C	0 to +40														
		F	32 to 104														
Lubrication			Lubricated for life														
Paint			Blue RAL 5002														
Direction of rotation			Motor and gearhead opposite directions														
Protection class			IP 65														
Moment of inertia (relates to the drive) Clamping hub diameter [mm]	G	24	$J_f$	kgcm <sup>2</sup>	5.96	4.30	3.90	3.32	3.31	2.80	3.18	2.80	2.49	2.73	2.49	2.73	2.46
				10 <sup>-3</sup> in.lb.in <sup>2</sup>	5.28	3.81	3.45	2.94	2.93	2.48	2.82	2.47	2.21	2.42	2.20	2.42	2.18
	K	38	$J_f$	kgcm <sup>2</sup>	12.87	11.19	10.81	10.23	10.22	9.72	10.09	9.71	9.40	9.65	9.40	9.65	9.37
				10 <sup>-3</sup> in.lb.in <sup>2</sup>	11.39	9.91	9.57	9.05	9.05	8.60	8.93	8.59	8.32	8.54	8.32	8.54	8.29

<sup>a)</sup> Other ratios available on request

<sup>b)</sup> Higher speeds are possible if the nominal torque is reduced

<sup>c)</sup> For higher ambient temperatures, please reduce input speed

<sup>d)</sup> Idling torques decrease during operation

<sup>e)</sup> Refers to center of the output shaft or flange

All technical data for front output side applies.

Technical data for rearward output versions, see page 386.

Please contact us for information on the best configuration for S1 conditions of use (continuous operation).

View A

4-stage:

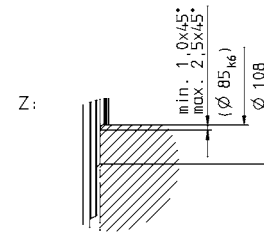
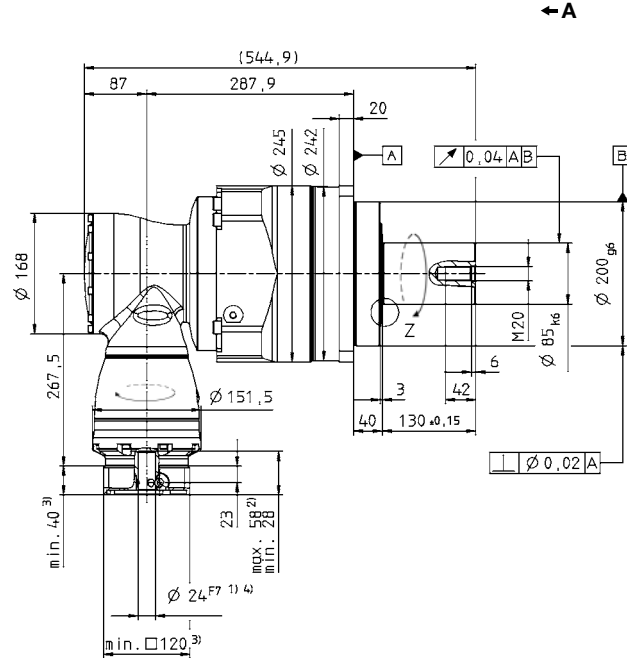
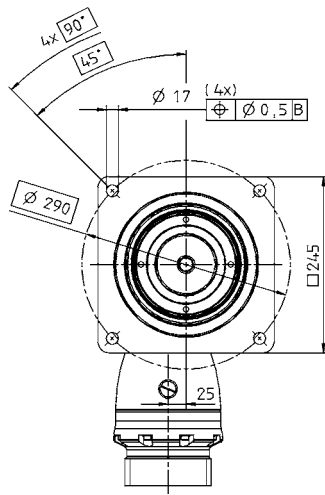

Alternatives: Output shaft variants

Keywayed output shaft in mm  
E = key as per DIN 6885, sheet 1, form A

Involute gearing DIN 5480 in mm  
X = W 80 x 2 x 30 x 38 x 6m, DIN 5480

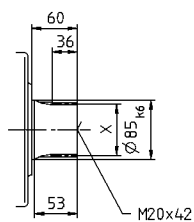
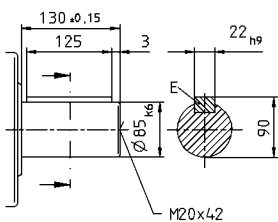

See technical data sheet for available clamping hub diameters (mass moment of inertia). Dimensions available on request.

Non-tolerated dimensions ±1 mm

- 1) Check motor shaft fit.
- 2) Min./Max. permissible motor shaft length. Longer motor shafts are adaptable, please contact us.
- 3) The dimensions depend on the motor.
- 4) Smaller motor shaft diameter is compensated by a bushing with a minimum thickness of 1 mm.

CAD data is available under [www.wittenstein-alpha.com](http://www.wittenstein-alpha.com)

Motor mounting according to operating manual

# SPK+ 240 MF 4-stage i=1225-10000

		4-stage											
Ratio <sup>a)</sup>		<i>i</i>	1225	1400	1750	2000	2800	3500	5000	7000	10000		
Max. acceleration torque (max. 1000 cycles per hour)	$T_{2B}$	Nm	4500	4500	4500	4200	4300	4500	4300	4300	3400		
		in.lb	39825	39825	39825	37170	38055	39825	38055	38055	30090		
Nominal output torque (with $n_{in}$ )	$T_{2N}$	Nm	2500	2500	2500	2500	2300	2500	2500	2300	1700		
		in.lb	22125	22125	22125	22125	20355	22125	22125	20355	15045		
Emergency stop torque (permitted 1000 times during the service life of the gearhead)	$T_{2Not}$	Nm	8500	8500	8500	8000	8500	8500	8500	8500	6800		
		in.lb	75225	75225	75225	70800	75225	75225	75225	75225	60180		
Nominal input speed (with $T_{2N}$ and 20°C ambient temperature) <sup>b), c)</sup>	$n_{1N}$	rpm	2900	2900	3200	3900	3900	3900	3900	3900	3900		
Max. continuous speed (with 20% $T_{2N}$ and 20°C ambient temperature)	$n_{1Ncym}$	rpm	4000	4000	4200	4200	4200	4200	4200	4200	4200		
Max. input speed	$n_{1Max}$	rpm	4500	4500	4500	4500	4500	4500	4500	4500	4500		
Mean no load running torque (with $n_1=3000$ rpm and 20°C gearhead temperature) <sup>d)</sup>	$T_{012}$	Nm	0.6	0.6	0.4	0.4	0.4	0.4	0.4	0.3	0.3		
		in.lb	5.3	5.3	3.5	3.5	3.5	3.5	3.5	2.7	2.7		
Max. torsional backlash	$j_t$	arcmin	Standard $\leq 5,5$ / Reduced $\leq 3,5$										
Torsional rigidity	$C_{t21}$	Nm/ arcmin	510	510	510	510	510	510	510	510	510		
		in.lb/ arcmin	4.514	4.514	4.514	4.514	4.514	4.514	4.514	4.514	4.514		
Max. axial force <sup>e)</sup>	$F_{2AMax}$	N	33000										
		lb <sub>f</sub>	7425										
Max. radial force <sup>e)</sup>	$F_{2RMax}$	N	30000										
		lb <sub>f</sub>	6750										
Max. tilting moment	$M_{2KMax}$	Nm	5000										
		in.lb	44250										
Efficiency at full load	$\eta$	%	90										
Service life (For calculation, see the Chapter "Information")	$L_h$	h	> 20000										
Weight incl. standard adapter plate	<i>m</i>	kg	96										
		lb <sub>m</sub>	212										
Operating noise (with $n_1=3000$ rpm no load)	$L_{PA}$	dB(A)	$\leq 71$										
Max. permitted housing temperature		°C	+90										
		F	194										
Ambient temperature		°C	0 to +40										
		F	32 to 104										
Lubrication			Lubricated for life										
Paint			Blue RAL 5002										
Direction of rotation			Motor and gearhead opposite directions										
Protection class			IP 65										
Moment of inertia (relates to the drive) Clamping hub diameter [mm]	G	24	$J_f$	kgcm <sup>2</sup>	2.73	2.49	2.46	2.42	2.42	2.42	2.42	2.42	2.42
				10 <sup>-3</sup> in.lb.s <sup>2</sup>	2.42	2.20	2.17	2.14	2.14	2.14	2.14	2.14	2.14
	K	38	$J_f$	kgcm <sup>2</sup>	9.64	9.40	9.37	9.33	9.33	9.33	9.33	9.33	9.33
				10 <sup>-3</sup> in.lb.s <sup>2</sup>	8.53	8.32	8.29	8.26	8.26	8.26	8.26	8.26	8.26

<sup>a)</sup> Other ratios available on request

<sup>b)</sup> Higher speeds are possible if the nominal torque is reduced

<sup>c)</sup> For higher ambient temperatures, please reduce input speed

<sup>d)</sup> Idling torques decrease during operation

<sup>e)</sup> Refers to center of the output shaft or flange

All technical data for front output side applies.

Technical data for rearward output versions, see page 386.

Please contact us for information on the best configuration for S1 conditions of use (continuous operation).

View A

4-stage:

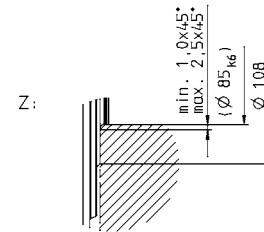
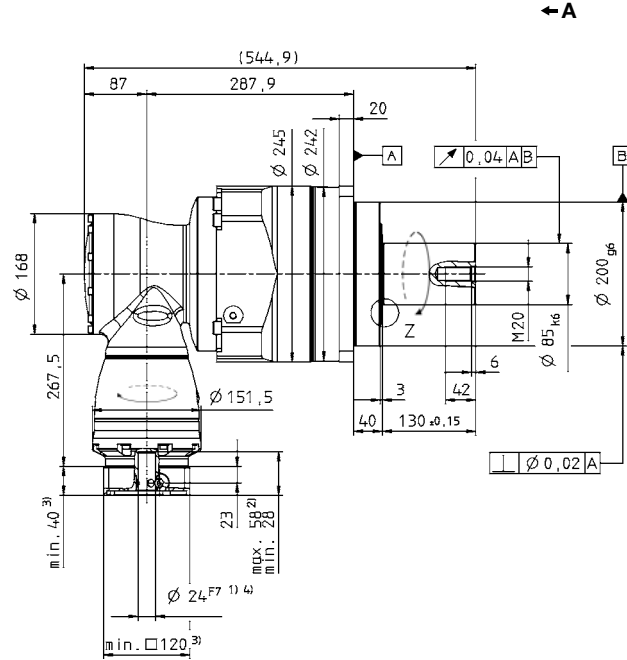
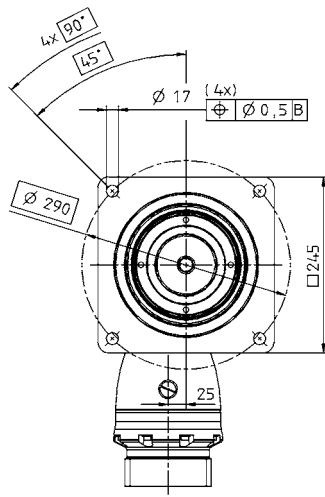

Alternatives: Output shaft variants

Keywayed output shaft in mm  
E = key as per DIN 6885, sheet 1, form A

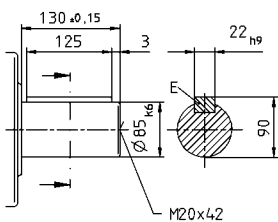

Involute gearing DIN 5480 in mm  
X = W 80 x 2 x 30 x 38 x 6m, DIN 5480

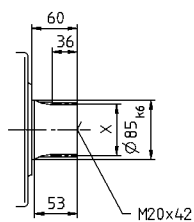

See technical data sheet for available clamping hub diameters (mass moment of inertia). Dimensions available on request.

Non-tolerated dimensions ±1 mm

- 1) Check motor shaft fit.
- 2) Min./Max. permissible motor shaft length. Longer motor shafts are adaptable, please contact us.
- 3) The dimensions depend on the motor.
- 4) Smaller motor shaft diameter is compensated by a bushing with a minimum thickness of 1 mm.

CAD data is available under [www.wittenstein-alpha.com](http://www.wittenstein-alpha.com)

Motor mounting according to operating manual